

120cm Series 9 Box Chimney Wall Rangehood

Contemporary

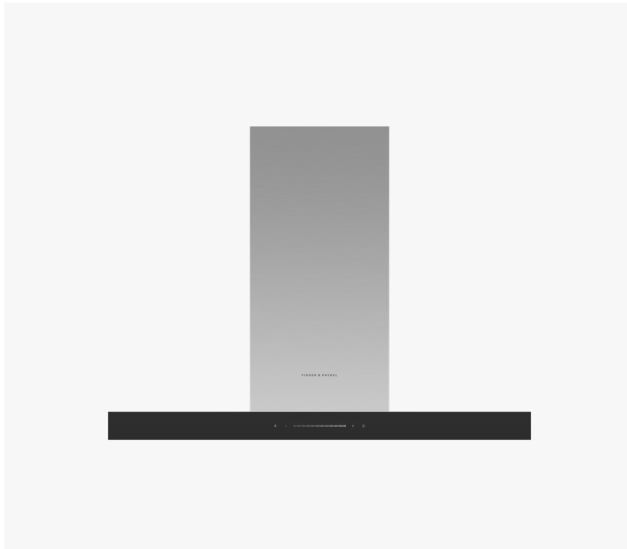

This Contemporary style rangehood has a large capture area, with powerful airflow for efficient extraction of steam, grease and cooking odours.

- With up to 21 fan speeds, select the perfect extraction rate for your cooking
- Powerful maximum air movement of 1200m³/hr, plus a boost function
- Perimeter extraction for efficient removal of steam and odours
- Dimmable LED lighting to illuminate your cooking surface

DIMENSIONS

Height	675 mm
Width	1200 mm
Depth	500 mm

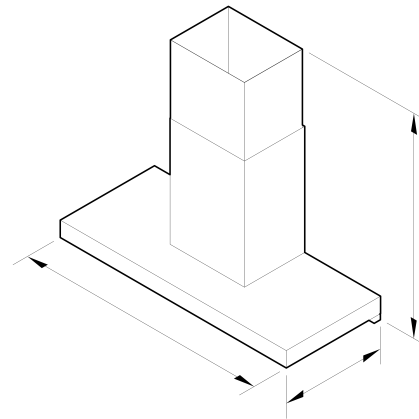

FEATURES & BENEFITS

Effective Extraction

Featuring up to 21 fan speeds, plus a boost function, this rangehood provides powerful extraction to quickly remove odours and steam. The large t-style design ensures perimeter extraction over cooktops of any size.

Grease Capture

An easy-to-remove oil cup captures any excess cooking grease and oils that accumulate during extraction. Simply remove and empty the cup when full, to ensure you get the best performance out of your rangehood.

Simple To Use

This rangehood is easy to use with a sleek, intuitive control panel with 21 touch and slide speed levels. Low energy, dimmable LED lights provide superb illumination over the entire cooking surface.

Easy Installation

This wall chimney rangehood is the ideal partner to your Fisher & Paykel cooktop. It is externally ducted, making it perfect for apartments.

Complementary Design

This wall chimney rangehood features sleek black glass and stainless steel styling that will complement any contemporary kitchen, and is designed to match the rest of Fisher & Paykel's kitchen appliance family.

Energy Efficiency

Powered by a brushless DC motor, this rangehood operates more efficiently, more reliably and with less noise than units with AC motors.

SPECIFICATIONS

Accessories (sold separately)

Ducting solution •

Fan ratings

Maximum air movement **1500 m³/hr**

Installation and cleaning

Ducted	Top extraction
--------	-----------------------

Performance

Fan speeds	21
Fan speeds + boost	.

Power requirements

Lighting power	10 W
Supply frequency	50 Hz
Supply voltage	220-240 V

Product dimensions

Depth	500 mm
Height	675 mm
Width	1200 mm

Ventilation features

Light type	LED
------------	------------

SKU	50234
-----	--------------

The product dimensions and specifications in this page apply to the specific product and model. Under our policy of continuous improvement, these dimensions and specifications may change at any time. You should therefore check with Fisher & Paykel's Customer Care Centre to ensure this page correctly describes the model currently available. © Fisher & Paykel Appliances Ltd 2020

Other product downloads available at fisherpaykel.com

- [↓](#) DWG
- [↓](#) DXF
- [↓](#) Data Sheet (English)
- [↓](#) Revit
- [↓](#) Rhino
- [↓](#) SketchUp
- [↓](#) Installation & User Guide (English)
- [↓](#) Installation & User Guide (Chinese)

Where applicable:

All appliances use energy, and energy usage typically generates carbon emissions. **Fisher & Paykel Appliances' In-use Energy Carbon Emissions Estimate** indicates carbon emissions from a product's in-use energy. This is calculated either annually or per cycle, using the product's market-specific energy label energy consumption data multiplied by the carbon emissions factor for energy in your country or region.

Our In-use Energy Carbon Emissions Estimate is designed to assist customers in making informed purchasing decisions when comparing different Fisher & Paykel products. For example, a heat pump dryer typically has a lower In-use Energy Carbon Emissions Estimate than a vented dryer.