

Integrated Dishwasher, 24"

Series 5 | Integrated

Panel Ready



Offering a superior wash performance, this Dishwasher is panel ready and designed to be integrated into your kitchen for a seamless look.

- Customize with your own front panel and handle to match your kitchen cabinetry
- Six wash programs to suit any load, from Delicate to Heavy
- Auto option senses the optimum wash cycle for your dishes

DIMENSIONS

Height	32 5/16 - 36 1/2"
Width	23 3/4"
Depth	22 3/4"

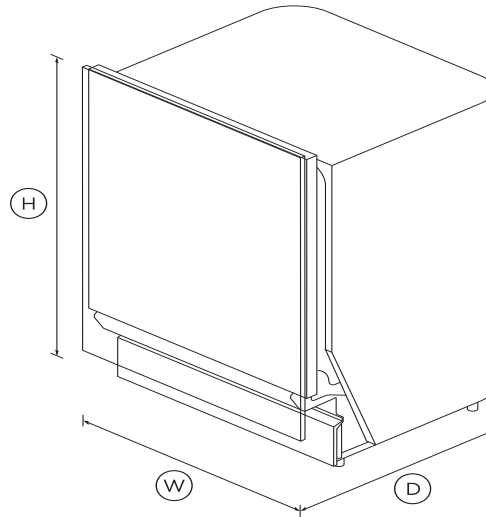

FEATURES & BENEFITS

Sized to suit

Install this fully integrated dishwasher to tall (American size) or short (Euro/ADA size) counter heights, ensuring minimal gaps. Customize with a front panel to match kitchen cabinetry.

A quality wash

This dishwasher offers six wash programs including Auto, which automatically senses the optimal wash cycle for your dishes. A three stage filtration system delivers a superior clean, while the rinse aid indicator reminds you to top up for squeaky-clean

dishes.

Flexible stacking

Flexible, adjustable storage lets you stack even large items with ease. This model features a removable cutlery tray, height adjustable middle rack, cup holders and wine glass supports.

Quiet and reliable

Running at a very low decibel level, this dishwasher does its job without making a fuss. The combination of clever technology and simple mechanics offers greater reliability and superior wash performance.

SPECIFICATIONS

Accessories

Kickstrip •

Accessories (sold separately)

Door panel stainless steel	AD-DW ADA
Handle kit Classic	AHCL-DDD-24X
Handle kit Contemporary	AHS-OBDD-60S
Handle kit Contemporary	AHD5-OBDD-60SX
Handle kit Contemporary	AHD5-OBDD-60SXB
Handle kit Contemporary	AHD3-OBDD-60S
Handle kit Professional round	AHP3-DWDD-SX

Capacity and loading

Accommodates round plates	10 1/4"
Fold down tines	•
Height adjustable top basket	•
Place settings	12
Wine glass supports	•

Consumption

Energy usage	232kWh/year
In-use energy carbon	85.0kgCO2e/year
Water usage (per wash cycle)	3.4 gal

Controls

End of cycle beeps	•
Energy saving delay start	•
Keylock	•
Rinse aid indicator light	•

Features

Quiet operation	•
ThermoDry system	•
Three-stage filtration system	•
Variable wash pressure	•

Performance

Noise emissions	48dBA
-----------------	-------

Power requirements

Amperage	10A
Supply frequency	50Hz
Supply voltage	220 - 240V

Product dimensions

Depth	22 3/4"
Height	32 5/16 - 36 1/2"
Width	23 3/4"

Safety and compliance

ADA compliant	•
---------------	---

Warranty

Parts and labor	2 years
-----------------	---------

Wash Programs

Auto	•
Eco	•
Fast	•
Heavy	•
Medium	•
Rinse	•
Wash programs	6

Water connection

Water pressure	100kPa - 1000kPa
----------------	------------------

SKU	81871
-----	-------

The product dimensions and specifications in this page apply to the specific product and model. Under our policy of continuous improvement, these dimensions and specifications may change at any time. You should therefore check with Fisher & Paykel's Customer Care Centre to ensure this page correctly describes the model currently available. ? Fisher & Paykel Appliances Ltd 2020

Other product downloads available at fisherpaykel.com

↓	Quick Start Guide
↓	User Guide EN
↓	Service & Warranty
↓	Energy Label Integrated Dishwasher
↓	Installation Guide EN
↓	Guide d'installation FR

**A PEACE OF MIND SALE**

24 Hours 7 Days a Week Customer Support

T 1.888.936.7872 Wwww.fisherpaykel.com