

Wall Cooker Hood, 90cm, Tilt Chimney

Series 7 | Contemporary

Stainless Steel and Glass



With a tilted black glass hood, this ventilation option saves on space while adding contemporary design to your kitchen.

- With four fan speeds, plus boost function, select the perfect extraction rate for your cooking
- Powerful maximum air movement 617m³/hr
- Dishwasher safe filters that are easy to remove and clean

DIMENSIONS

Height	800-1140mm
Width	900mm
Depth	380mm

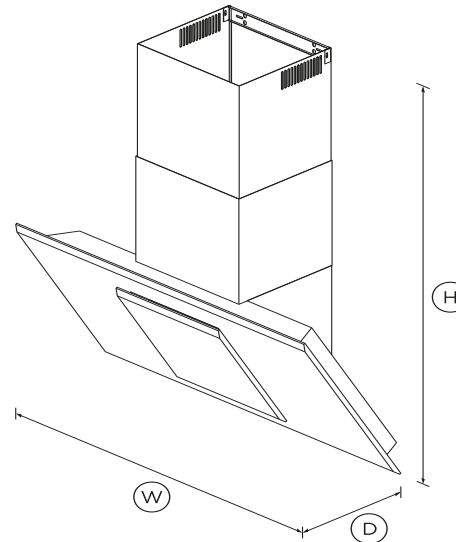

FEATURES & BENEFITS

Effective and quiet

This cooker hood features four fan speeds, plus a boost function, providing powerful extraction to quickly remove odours and steam. As odours can linger in the kitchen well after cooking is finished, the timer keeps the rangehood working for up to 15 minutes before automatically turning off.

Simple to use

This Fisher & Paykel tilt cooker hood features a sleek and easy to use touch-control panel. Low energy, dimmable LED lights

provide superb illumination over the entire cooking surface.

Easy cleaning

Designed for simple removal, the filters are easy to clean and dishwasher safe. The black glass finish just needs a quick wipe to keep clean. An alert reminds you when to clean the filter to ensure you get the best performance out of your cooker hood.

Designed to match

This wall chimney tilt cooker hood features sleek black glass and stainless steel styling which will complement any contemporary kitchen and is designed to match the rest of Fisher & Paykel's kitchen appliance family.

SPECIFICATIONS

Accessories

Aluminium filter	791761
------------------	--------

Accessories (sold separately)

Eave ducting kit	PD-RHK15OE
Light bulb	792556
Recirculation diverter	791820
Roof ducting kit	PD-RHK15OR
Side wall ducting kit	PD-RHK15OW

Consumption

Energy rating	B
Energy usage	47kWh/year
In-use energy carbon	14.5kgCO ₂ e/year

Fan ratings

Maximum air movement	617m ³ /hr
Maximum pressured air	617m ³ /hr

Maximum sound rating **69dB**

Installation and cleaning

Dishwasher safe filters **1**

Ducted **Top and back extraction**

Recirculation **Optional - top extraction**

Two piece height adjustable **•**

Performance

Extraction type **Perimeter**

Fan speeds **4**

Filter type **Mesh with perimeter**

Number of filters **1**

Power requirements

Lighting power **7W**

Motor power **130W**

Rated current **3A**

Supply frequency **50Hz**

Supply voltage **220-240V**

Total Power **130W**

Product dimensions

Depth **380mm**

Height **800-1140mm**

Width **900mm**

Product information

Control type **Capacitive touch**

Ventilation features

Dimmable lights **•**

Filter cleaning alert **•**

Light type **LED**

Timer function **•**

Warranty

Parts and labour **5 years**

SKU **50124**

The product dimensions and specifications in this page apply to the specific product and model. Under our policy of continuous improvement, these dimensions and specifications may change at any time. You should therefore check with Fisher & Paykel's Customer Care Centre to ensure this page correctly describes the model currently available. ? Fisher & Paykel Appliances Ltd 2020

Other product downloads available at fisherpaykel.com

- [↓](#) Service & Warranty
- [↓](#) User Guide
- [↓](#) Installation Guide
- [↓](#) Data Sheet Wall Rangehood



A PEACE OF MIND SALE

24 Hours 7 Days a Week Customer Support

T 1800 625174 Wwww.fisherpaykel.com