

Dual Fuel Range, 30", 4 Burners

Series 9 | Professional

Stainless Steel | LPG



Make a statement in your kitchen with this Professional style range for powerful gas and convection cooking.

- Top burner heat of 19,000 BTU, for seriously fast boiling
- Convection oven with 4 cu ft total capacity
- Non-tip full-extension shelves for safe removal of hot dishes

DIMENSIONS

Height	35 3/4 - 36 3/4"
Width	29 7/8"
Depth	29 1/8"

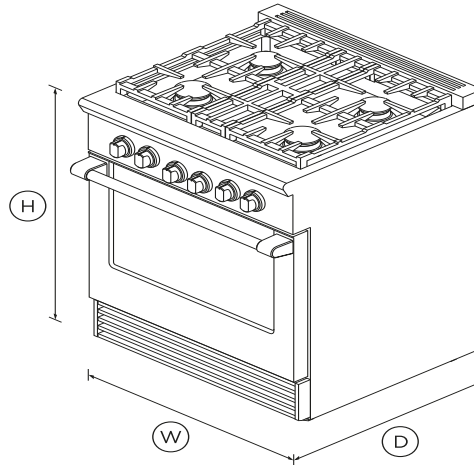

FEATURES & BENEFITS

Cooktop power

Sealed Dual Flow Burners™ deliver cooktop power up to 22,500 BTU (NG models) for seriously fast boiling right down to a precise 140°F full surface simmer with the gentlest of flames.

Total control

Precise control across high and low settings is delivered through the halo-illuminated cooktop dials. The ovens have true convection and electronic oven control for precise and consistent temperatures.

Consistent broiling

The Dual Fuel Range broiler provides an even heat that covers a very large surface area — perfect for browning a fully loaded oven tray.

Easy to clean

The Dual Fuel Range oven has a self-cleaning function and removable side racks. The cooktop has sealed burners and an encapsulated cooking surface with a commercial-style stainless steel finish.

Instant visibility

Control dials have halo-illumination glowing white – heating up; orange – temperature reached; red – self-cleaning mode. The oven is illuminated by two powerful incandescent lights.

COOKING FLEXIBILITY

The cooktop is designed for easy access to any burner with grates you can smoothly slide pots across. The oven is large enough to hold full size baking sheets.

SPECIFICATIONS

Accessories (sold separately)

Square handle option	AH-R30
----------------------	--------

Burner ratings

Maximum burner power	19000 BTU
Power back left	13000BTU
Power back right	13000BTU
Power front left	19000BTU
Power front right	15000BTU
Total cooktop power	60000 BTU

Capacity

Shelf positions (main oven)	5
-----------------------------	---

Total capacity (main oven)	4L
----------------------------	----

Cleaning

Pyrolytic self-clean	•
----------------------	---

Controls

Electric circuit	4 wire
------------------	--------

Metal illuminated dials	•
-------------------------	---

Gas Requirements

Fitting and pipe	½ NPT, min. ⅝" flex line
------------------	--------------------------

Supply Pressure (LPG)	11" to 14" W.C
-----------------------	----------------

Oven features

Auto re-ignition system	•
-------------------------	---

Broil pan	•
-----------	---

Concealed element	•
-------------------	---

Electronic oven control	•
-------------------------	---

Internal light	•
----------------	---

True convection	•
-----------------	---

Oven functions

Bake	•
------	---

Broil	•
-------	---

Clean	•
-------	---

Convection Broil	•
------------------	---

Convection bake	•
-----------------	---

Number of functions	6
---------------------	---

True convection	•
-----------------	---

Oven performance

Bake power	3500
------------	------

Main oven - True convection	2500W
-----------------------------	-------

Power requirements

Rated current	30A
---------------	-----

Supply frequency	60Hz
------------------	------

Product dimensions

Depth	29 1/8"
-------	---------

Height	35 3/4 - 36 3/4"
--------	------------------

Width	29 7/8"
-------	---------

Rangetop features

Sealed range top	•
------------------	---

Vent trim included	•
--------------------	---

Safety

Full extension telescopic	•
---------------------------	---

SKU	71373
-----	-------

The product dimensions and specifications in this page apply to the specific product and model. Under our policy of continuous improvement, these dimensions and specifications may change at any time. You should therefore check with Fisher & Paykel's Customer Care Centre to ensure this page correctly describes the model currently available. © Fisher & Paykel Appliances Ltd 2020

Other product downloads available at fisherpaykel.com



Service & Warranty



User Guide EN



Installation Guide EN / Guide d'installation FR



Data Sheet Dual Fuel Range



Planning Guide Dual Fuel Range



A PEACE OF MIND SALE

24 Hours 7 Days a Week Customer Support

T 1.888.936.7872 [Wwww.fisherpaykel.com](http://www.fisherpaykel.com)