

60CM CONTEMPORARY OVENS

PLANNING GUIDE

SERIES 5 PYROLYTIC OVEN | OB60SBCPGB5

INTRODUCTION

This comprehensive planning guide provides you with the framework and tools to achieve your desired design outcome with Fisher & Paykel appliances. In this guide, you will find a range of conceptual, detailed, and dimensional product information to bring your ideas to life and create spaces that truly reflect your vision.

SUPPORT

For additional design planning and installation support please contact the Fisher & Paykel design support team.
designsupport@fisherpaykel.com

NOTES

The models shown in this Planning Guide may not be available in all markets and are subject to change at any time. Refer to our website fisherpaykel.com for the latest document version. Product specifications may vary from those shown. This Planning Guide should not be used as installation guidance for any product. Specific installation guidance will be available with the product on delivery and on our website.

CONCEPT DESIGN **PAGE**

SPECIFICATION GUIDE

Pyrolytic Oven	4
Pyrolytic Oven Specification	5

DEVELOPED AND DETAILED DESIGN **PAGE**

DEVELOPED AND DETAILED DESIGN **PAGE**

SPECIFICATION GUIDE

SERIES 5



OVERVIEW

Designed to be distinctive and timeless, this Contemporary oven complements a wide range of kitchen styles. The pyrolytic self-cleaning function breaks down food residue for an easy clean, while the dial control with illuminated icons offers simple operation of 9 versatile functions including Air Fry and Pizza Bake.

PRODUCTS

OB60SBCPGB5 - Black
60cm Series 5 Contemporary Pyrolytic Oven



SERIES & STYLE

Series 5
Contemporary

FEATURES

- ① Contemporary style is distinctive and timeless to complement a wide range of kitchen styles
- ② Self-cleaning pyrolytic function breaks down food residue for an easy clean
- ③ Generous 72L useable capacity
- ④ Dial control with illuminated icons for simple operation
- ⑤ Even heat distribution thanks to AeroTech™ technology
- ⑥ 9 versatile functions including Air Fry and Pizza Bake

ACCESSORIES

- ① Pyro-proof Side Ladders
- ② Wire Shelf
- ③ Multi-functional Air Fry Tray
- ④ Roasting Dish

The models shown in this Planning Guide may not be available in all markets and are subject to change at any time. Product specifications may vary from those shown. This Planning Guide should not be used as installation guidance for any product. Further information is required to safely and correctly install the products featured here. Specific installation guidance will be available with the product on delivery and on our website fisherpaykel.com

SPECIFICATIONS

MODEL NUMBER

OB60SBCPGB5 60cm Series 5 Contemporary Pyrolytic Oven - Black

ELECTRICAL

Dedicated Circuit (A)	16
Rated Power (W)	2800 - 3300
Supply (Hz)	50
Voltage (V)	220 - 240
Connection	Hard-wired, min 1500mm*

*The electrician provides sufficient free length of power supply cable to reach from the bottom rear of the cavity to at least 1.5m in front of the bottom edge of the opening.

Note: For multi-residential installs, use the Rated Power to calculate the demand.

CAPACITY

Total Oven capacity	85L
---------------------	-----

PRODUCT DIMENSIONS

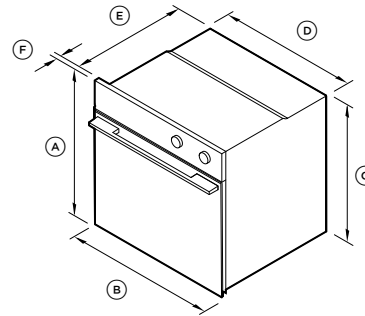

ISOMETRIC VIEW

	mm
(A) Overall height	598
(B) Overall width	596
(C) Chassis height	575
(D) Chassis width	556
(E) Chassis depth	545
(F) Control panel thickness	20
Depth with door fully open*	447

*Measured from front of control panel.

CAVITY DIMENSIONS

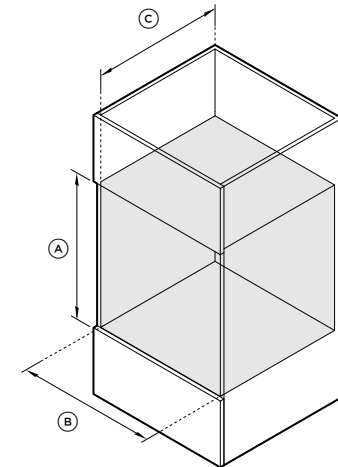

ISOMETRIC VIEW

	mm
(A) Minimum inside height of cavity	580
(B) Minimum inside width of cavity	560
(C) Minimum inside depth of cavity*	550
Recommended cabinet height	600
Recommended cabinet width	600

*Measured from front of chassis.

