

Single DishDrawer™ Dishwasher, Tall, Sanitize

Series 9 | Contemporary

Stainless Steel



With internal controls for a clean exterior aesthetic. The top drawer will fit your large dinner plates easily.

- Six wash programs, as well as additional Quick wash, Sanitize and Extra Dry options
- American Disabilities Act (ADA) compliant, this can be installed at an accessible height for loading and unloading
- Flexible racking can be folded down to fit bigger dishes

DIMENSIONS

Height	18 13/16"
Width	23 9/16"
Depth	22 9/16"

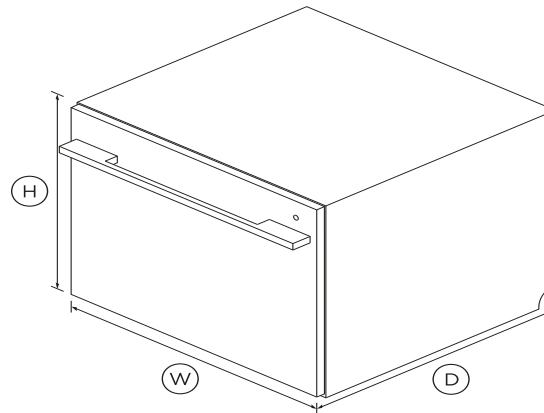

FEATURES & BENEFITS

Ease Of Use

DishDrawer™ Dishwashers are as easy to open and close as kitchen drawers and can be conveniently positioned at bench height for ease of loading and minimal bending. Flexible racking allows you to make adjustments to fit in a variety of dishes.

Complementary design

DishDrawer™ Dishwashers can be installed in any kitchen space and are designed to match the Fisher & Paykel family of kitchen appliances, with matching handles, premium styling and quality

materials.

Quick, Sanitize and Extra Dry options

The Quick wash modifier delivers a faster wash while maintaining performance. The Sanitize option provides extra protection killing 99.9% of bacteria in the final rinse. The Extra Dry setting is perfect for plastic dishes.

QUIET PERFORMER

Running at a very low decibel rate, these DishDrawer™ Dishwashers do their job without making a fuss. The combination of intelligent technology and simple mechanics means greater reliability and excellent wash performance.

SPECIFICATIONS

Accessories

- Cutlery basket
- Knife clip and multipurpose

Capacity and loading

Accommodates round plates	12.25"
Adjustable height, foldable	•
Fold down tines	•
Pitch adjustable tines	•
Place settings	7

Consumption

Energy rating	Energy star
Energy usage	144kWh/year
In-use energy carbon	52.8kgCO2e/year
Water usage (per wash cycle)	1.64 gal

Controls

- Electronic fault/Diagnostic
- End of cycle beeps
- Energy saving delay start
- Internal wash selector
- Keylock
- Rinse aid indicator light
- Wi-Fi connectivity

Features

- Fan assisted drying
- Flood protection
- Flow through detergent
- Quiet operation
- SmartDrive™ technology

Performance

Noise emissions **42dBA**

Power requirements

Amperage **5A**
 Electric circuit **3 wire**
 Rated current **15A**
 Supply frequency **60Hz**
 Supply voltage **100 - 120V**

Product dimensions

Depth **22 9/16"**
 Height **18 13/16"**
 Width **23 9/16"**

Safety and compliance

ADA compliant •

Warranty

Parts and labor **Limited 2 years**

Wash Program Modifiers

Extra Dry •
 Quick •
 Sanitize •
 Wash modifiers **3**

Wash Programs

Delicate •
 Eco •
 Fast •
 Heavy •
 Medium •
 Rinse •
 Wash programs **6**

Water connection

Supplied hose to suit 3/8" •
 Water pressure **30kPa - 1000 kPa**
 Water supply **3/8" to suit Male Compression**

SKU **82344**

The product dimensions and specifications in this page apply to the specific product and model. Under our policy of continuous improvement, these dimensions and specifications may change at any time. You should therefore check with Fisher & Paykel's Customer Care Centre to ensure this page correctly describes the model currently available. Fisher & Paykel Appliances Ltd 2020

Where applicable:

All appliances use energy, and energy usage typically generates carbon emissions. **Fisher & Paykel Appliances' In-use Energy Carbon Emissions Estimate** indicates carbon emissions from a product's in-use energy. This is calculated either annually or per cycle, using the product's market-specific energy label energy consumption data multiplied by the carbon emissions factor for energy in your country or region.

Our In-use Energy Carbon Emissions Estimate is designed to assist customers in making informed purchasing decisions when comparing different Fisher & Paykel products. For example, a heat pump dryer typically has a lower In-use Energy Carbon Emissions Estimate than a vented dryer.

Other product downloads available at fisherpaykel.com



Service & Warranty



Energy Label Single DishDrawer™ Dishwasher



User Guide DishDrawer™ Dishwasher EN



Quick Start Guide DishDrawer™ Dishwasher EN



Installation Guide Single DishDrawer™ Dishwasher EN



Data Sheet Single DishDrawer™ Dishwasher



A PEACE OF MIND SALE

24 Hours 7 Days a Week Customer Support

T 1.888.936.7872 **W** www.fisherpaykel.com