

# 473L Series 5 Refrigerator Freezer

Contemporary



With ample storage and a stylish stainless steel finish, for a timeless look.

- ActiveSmart™ technology helps keep food fresher for longer by constantly maintaining the ideal temperature.
- Spacious bottom freezer with easy-slide internal drawers to separate storage

## DIMENSIONS

Height	1715 mm
Width	790 mm

Depth

695 mm

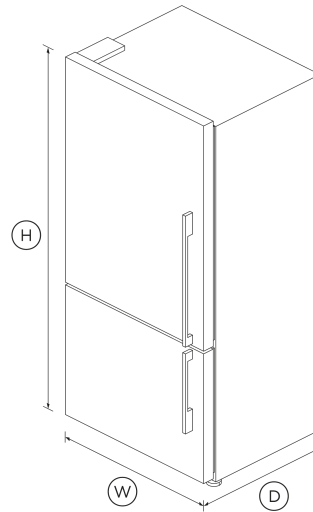

## FEATURES & BENEFITS

### Activesmart™ Foodcare

ActiveSmart™ Foodcare learns how you live. It's technology which understands how you use your refrigerator and adjusts temperature, airflow and humidity inside to help keep food fresher for longer.

### Simple storage

This refrigerator is designed to make it simple for you to store, access and remove food. Storage bins give you full access inside when they're pulled open and can be easily removed to clean. Our flexible shelving also gives you more storage options.

### CLEVER ENERGY

Your refrigerator adapts to daily use by cooling and defrosting only when needed. This means it uses the energy it needs without compromising on food care.

### Easy Cleaning

No more permanent dirty marks with our EZKleen feature for stainless steel fridges. Anti-fingerprint coating means you simply wipe clean any marks. Spill-safe secure glass shelves easily capture any drips or leaks.

### Design Quality

Our refrigerators are designed and built using quality materials. We use real stainless steel, and solid glass for shelving.

### Humidity Control

Your fruit and veges need different environments. The humidity control slides in each storage bin create a perfect microclimate for each, which helps keep them fresher for longer.

## SPECIFICATIONS

### Capacity

Total gross capacity	519 L
Total net volume	463L
Volume	494 L
Volume freezer	146 L
Volume refrigerator	348 L

### Consumption

Energy consumption	475kWh/year
Energy rating	2 ticks

**Features**

Adjustable door shelves	4
Adjustable glass shelves	4
Covered door shelves	2
Door alarm	•
Front levelling feet	•
Fruit and vegetable bins	2
Full extension runners	•
Full width door shelves	2
LED lighting	•
Single bottle holders	4
SmartTouch control panel	•

**Freezer Features**

Bottle chill	•
Door alarm	•
Fast freeze	•
Ice trays	2
Large plastic bins	•
Slide Out Pastry Tray	•
Small plastic bins	•

**Performance**

ActiveSmart™ Foodcare	•
Adaptive defrost	•
Frost free	•
Frost free freezer	•
Humidity control system	•
Inverter controlled compressor	•

Sabbath mode •

**Power requirements**

Rated current	10 A
Supply frequency	50 Hz
Supply voltage	230 V

**Product dimensions**

Depth	695 mm
Depth (including handles)	730 mm
Height	1715 mm
Height to top of cabinet	1715 mm
Minimum air clearance - each side	20 mm
Minimum air clearance - on top	50 mm
Width	790 mm

SKU 26182

The product dimensions and specifications in this page apply to the specific product and model. Under our policy of continuous improvement, these dimensions and specifications may change at any time. You should therefore check with Fisher & Paykel's Customer Care Centre to ensure this page correctly describes the model currently available. © Fisher & Paykel Appliances Ltd 2020

**Other product downloads available at [fisherpaykel.com](http://fisherpaykel.com)**

[↓](#) DWG

- [↓](#) DWG
- [↓](#) DXF
- [↓](#) DXF
- [↓](#) Data Sheet (English)
- [↓](#) Installation Guide (English)
- [↓](#) User Guide (English)
- [↓](#) Installation & User Guide (English)

**Where applicable:**

All appliances use energy, and energy usage typically generates carbon emissions. **Fisher & Paykel Appliances' In-use Energy Carbon Emissions Estimate** indicates carbon emissions from a product's in-use energy. This is calculated either annually or per cycle, using the product's market-specific energy label energy consumption data multiplied by the carbon emissions factor for energy in your country or region.

Our In-use Energy Carbon Emissions Estimate is designed to assist customers in making informed purchasing decisions when comparing different Fisher & Paykel products. For example, a heat pump dryer typically has a lower In-use Energy Carbon Emissions Estimate than a vented dryer.



**A PEACE OF MIND SALE**  
**24 Hours 7 Days a Week Customer Support**  
 T +65 6741 0777 W [www.fisherpaykel.com](http://www.fisherpaykel.com)