

# Freestanding Refrigerator Freezer, 79cm, 491L

Series 5 | Contemporary

Stainless Steel | Left hinge



With ample storage and a stylish stainless steel finish, for a timeless look.

- ActiveSmart™ technology helps keep food fresher for longer by constantly maintaining the ideal temperature.
- Spacious bottom freezer with full extension drawer gives easy access to frozen goods.

## DIMENSIONS

Height	1715mm
Width	790mm
Depth	695mm

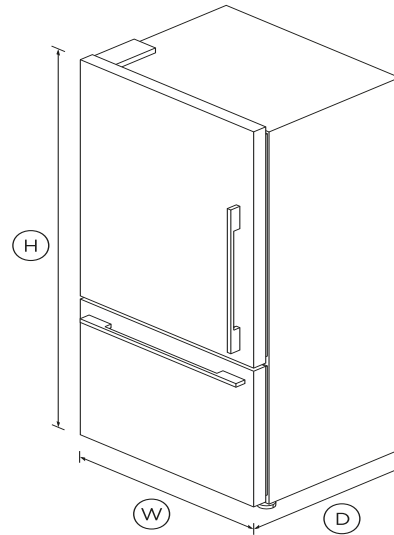

## FEATURES & BENEFITS

### Activesmart™ Foodcare

ActiveSmart™ Foodcare learns how you live. It's technology which understands how you use your refrigerator and adjusts temperature, airflow and humidity inside to help keep food fresher for longer.

### Design quality

Our refrigerators are designed and built using quality materials. We use real stainless steel, and solid glass for shelving.

## CLEVER ENERGY

Your fridge adapts to daily use by cooling and defrosting only when needed. This means your fridge uses the energy it needs without compromising on food care.

### Simple Storage

This refrigerator is designed to make it simple for you to store, access and remove food. Storage bins give you full access inside when they're pulled open and can be easily removed to clean. Our flexible shelving also gives you more storage options.

### Easy Cleaning

No more permanent dirty marks with our EZKleen feature for stainless steel refrigerators. Anti-fingerprint coating means you simply wipe clean any marks. Spill-safe secure glass shelves easily capture any drips or leaks.

### Humidity Control

Your fruit and veges need different environments. The humidity control slides in each storage bin create a microclimate that helps keep food fresher for longer.

## SPECIFICATIONS

### Capacity

Volume	491L
Volume freezer	143L
Volume refrigerator	348L

### Consumption

Energy rating	3.5 star
Energy usage	409kWh/year
In-use energy carbon	55.4kgCO2e/year

### Features

Adjustable door shelves	4
-------------------------	---

Adjustable glass shelves	4
Covered door shelves	2
Door alarm	•
Front levelling feet	•
Fruit and vegetable bins	2
LED lighting	•
Single bottle holders	4
SmartTouch control panel	•

Height	1715mm
Height to top of cabinet	1715mm
Width	790mm

**Warranty**

Parts and labour	2 years
Sealed system parts only	additional 3 years

SKU 26470

The product dimensions and specifications in this page apply to the specific product and model. Under our policy of continuous improvement, these dimensions and specifications may change at any time. You should therefore check with Fisher & Paykel's Customer Care Centre to ensure this page correctly describes the model currently available. Fisher & Paykel Appliances Ltd 2020

**Where applicable:**

All appliances use energy, and energy usage typically generates carbon emissions. **Fisher & Paykel Appliances' In-use Energy Carbon Emissions Estimate** indicates carbon emissions from a product's in-use energy. This is calculated either annually or per cycle, using the product's market-specific energy label energy consumption data multiplied by the carbon emissions factor for energy in your country or region.

Our In-use Energy Carbon Emissions Estimate is designed to assist customers in making informed purchasing decisions when comparing different Fisher & Paykel products. For example, a heat pump dryer typically has a lower In-use Energy Carbon Emissions Estimate than a vented dryer.

**Freezer Features**

- Bottle chill
- Door alarm
- Fast freeze
- Ice bin and scoop
- Large plastic bins
- Small plastic bins

**Performance**

- ActiveSmart™ Foodcare
- Adaptive defrost
- Frost free freezer
- Humidity control system
- Inverter controlled compressor
- R600a refrigerant

**Power requirements**

Supply voltage 220 - 240V

**Product dimensions**

Depth 695mm

**Other product downloads available at fisherpaykel.com**

- ↓ Service & Warranty
- ↓ Installation & User Guide Refrigerator
- ↓ Installation Guide
- ↓ Data Sheet Freestanding Refrigerator Freezer



**A PEACE OF MIND SALE**

**24 Hours 7 Days a Week Customer Support**

**T 0800 372 273 W www.fisherpaykel.com**