

90cm Series 7 Box Chimney Wall Rangehood

Contemporary



This wall chimney rangehood has smart technology that removes steam, grease and cooking odours quickly and efficiently while maintaining a stable extraction rate.

- Stable air extraction, perfect for high-rise apartments
- With three fan speeds plus a boost function that can achieve an extraction rate up to 20m³/min (1200m³/hr)
- Intuitive on and off gesture control
- Air purification function for cleaner air

DIMENSIONS

Height	620 - 1000 mm
Width	895 mm
Depth	520 mm

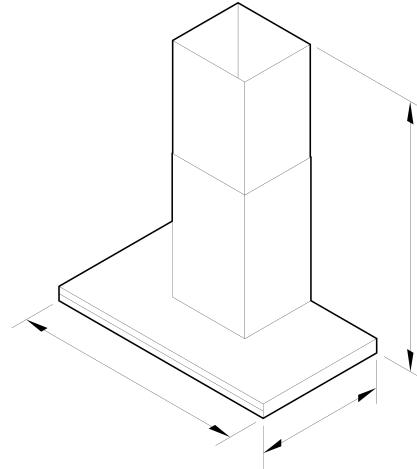

FEATURES & BENEFITS

Effective Extraction

Three airflow settings ensure that odours, vapour and steam are removed quickly, while a grease filtration system effectively captures grease and oil from the air stream. The additional Boost function can also achieve an impressive extraction rate of up to 20m³/min (1200m³/hr).

Adapts To Your Environment

With smart air capability, this rangehood doesn't just reach impressive extraction rates, it keeps it there. Our unique motor control design coupled with smart technology, adjusts to any environment to deliver constant extraction rates, which makes it perfect for any home, especially high-rise buildings and apartment living.

Simple To Use

Intuitive gesture control makes it easy to turn the rangehood on and off with a wave of your hand. A sleek, touch-control panel controls your fan speed as well as the low energy LED lights.

Cleaner Air

An intensive air purification function clears cooking vapours quickly and efficiently, leaving your kitchen air cleaner.

Seamless Integration

When not in use, the motorised central panel automatically closes, for a beautifully streamlined look. This rangehood features sleek black glass and stainless steel styling that will complement any contemporary kitchen.

Easy Installation

This wall chimney rangehood is the perfect partner to your Fisher & Paykel cooktop. It is externally ducted, making it perfect for apartments.

Easy Cleaning

An easy-to-remove drip tray captures any excess cooking oils that accumulate during extraction. Simply remove and empty the tray when full, to ensure you get the best performance out of your rangehood.

SPECIFICATIONS

Fan ratings

Maximum air movement

1200 m³/hr

Maximum sound rating **68 dBA**

Intelligent Air •

Light type **LED**

Installation and cleaning

Dishwasher safe filters **1**

Ducted **Top extraction only**

SKU **50239**

The product dimensions and specifications in this page apply to the specific product and model. Under our policy of continuous improvement, these dimensions and specifications may change at any time. You should therefore check with Fisher & Paykel's Customer Care Centre to ensure this page correctly describes the model currently available. © Fisher & Paykel Appliances Ltd 2020

Performance

Extraction type **Surface**

Fan speeds **3**

Fan speeds + boost •

Filter type **Stainless Steel Baffle**

Other product downloads available at fisherpaykel.com

- [↓](#) DWG
- [↓](#) DXF
- [↓](#) Archicad
- [↓](#) Data Sheet (English)
- [↓](#) Revit
- [↓](#) Rhino
- [↓](#) SketchUp
- [↓](#) Installation & User Guide (English)
- [↓](#) Installation & User Guide (Chinese)

Power requirements

Lighting power **3 W**

Supply frequency **50 Hz**

Supply voltage **220 - 240 V**

Where applicable:

All appliances use energy, and energy usage typically generates carbon emissions. **Fisher & Paykel Appliances' In-use Energy Carbon Emissions Estimate** indicates carbon emissions from a product's in-use energy. This is calculated either annually or per cycle, using the product's market-specific energy label energy consumption data multiplied by the carbon emissions factor for energy in your country or region.

Our In-use Energy Carbon Emissions Estimate is designed to assist customers in making informed purchasing decisions when comparing different Fisher & Paykel products. For example, a heat pump dryer typically has a lower In-use Energy Carbon Emissions Estimate than a vented dryer.

Product dimensions

Depth **520 mm**

Height **620 - 1000 mm**

Width **895 mm**

Ventilation features

Air quality sensor and purification function •

Gesture control •