

# Freestanding French Door Refrigerator Freezer, 79cm, 488L

Series 7 | Contemporary

Stainless Steel | French hinge



You'll have plenty of flexible storage space in this striking, large capacity French Door refrigerator freezer.

- ActiveSmart technology helps keep food fresher for longer by constantly maintaining the ideal temperature
- Spacious bottom freezer with full extension drawer gives easy access to frozen goods

## DIMENSIONS

Height	1715mm
Width	790mm
Depth	695mm

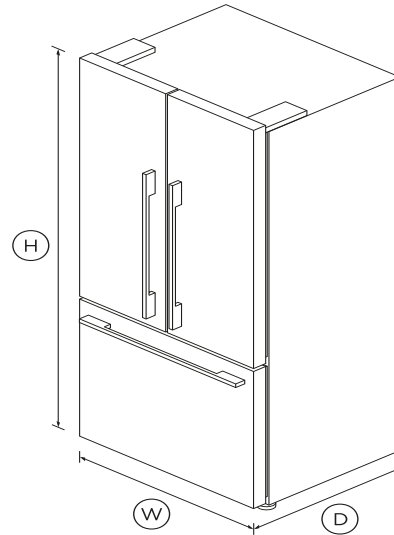

## FEATURES & BENEFITS

### Activesmart Foodcare

Every time you open your refrigerator, the temperature around your food changes. ActiveSmart foodcare adjusts airflow to create a stable temperature, helping your food stay fresher for longer.

### Simple Storage

This refrigerator is designed to make it simple for you to store, access and remove food. Storage bins give you full access inside when they're pulled open and can be easily removed to clean.

Our flexible shelving also gives you more storage options.

### Humidity control

Your fruit and veges need different environments. The humidity control slides in each storage bin create a microclimate that helps keep food fresher for longer.

### Easy cleaning

No more permanent dirty marks with our EZKleen feature for stainless steel refrigerators. Anti-fingerprint coating means you simply wipe clean any marks. Spill-safe secure glass shelves easily capture any drips or leaks.

### Design quality

Our refrigerators are designed and built using quality materials. We use real stainless steel, and solid glass for shelving.

### Clever Energy

Your refrigerator adapts to daily use by cooling and defrosting only when needed. This means it uses only the energy it needs without compromising on food care.

### Complementary design

With their premium handle styling and stainless steel finish, our refrigerators are designed to match the rest of Fisher & Paykel's kitchen appliance family.

## SPECIFICATIONS

### Accessories (sold separately)

Handle kit Contemporary	25334
-------------------------	-------

### Capacity

Total net volume	487L
Volume freezer	142L
Volume refrigerator	346L

### Consumption

Energy consumption	<b>361kWh/year</b>
Energy rating	<b>F</b>

---

### Features

Adjustable glass shelves	<b>2</b>
Adjustable half width door	<b>2</b>
Covered door shelves	<b>2</b>
Door alarm	<b>•</b>
Front levelling feet	<b>•</b>
Full extension runners	<b>•</b>
Full width door shelves	<b>2</b>
LED lighting	<b>•</b>
Rear rollers	<b>•</b>
Single bottle holders	<b>4</b>
SmartTouch control panel	<b>•</b>

---

### Freezer Features

Bottle chill	<b>•</b>
Door alarm	<b>•</b>
Fast freeze	<b>•</b>
Freezer bins	<b>3</b>

---

### Performance

ActiveSmart™ Foodcare	<b>•</b>
Adaptive defrost	<b>•</b>
Frost free freezer	<b>•</b>
Humidity control system	<b>•</b>
Inverter controlled compressor	<b>•</b>
R600a refrigerant	<b>•</b>
Sabbath mode	<b>•</b>

---

### Power requirements

Supply voltage	<b>220 - 240V</b>
----------------	-------------------

---

### Product dimensions

Depth	<b>695mm</b>
Height	<b>1715mm</b>
Width	<b>790mm</b>

---

### Warranty

Parts and labour	<b>5 years</b>
Sealed system parts only	<b>5 years</b>

---

SKU	<b>25448</b>
-----	--------------

---

The product dimensions and specifications in this page apply to the specific product and model. Under our policy of continuous improvement, these dimensions and specifications may change at any time. You should therefore check with Fisher & Paykel's Customer Care Centre to ensure this page correctly describes the model currently available. ? Fisher & Paykel Appliances Ltd 2020



### A PEACE OF MIND SALE

**24 Hours 7 Days a Week Customer Support**

**T 1800 625174 W www.fisherpaykel.com**