

Front Loader Washing Machine, 11kg, ActiveIntelligence™, Steam Care

Series 11 | Front Load

Graphite



Care for every corner of the wardrobe with a connected fabric care ecosystem. With 29+ cycles, this Steam Care washer combines with our Heat Pump Dryer and Fabric Care Cabinet to create an ultimate fabric care solution.

- Combine with a Heat Pump Dryer and Fabric Care Cabinet to create an ultimate fabric care ecosystem
- Centralised control - the intuitive touchscreen display can also control a display-free heat pump dryer*

- Refresh, revive and dewrinkle garments using the 20 minute Steam Refresh cycle
- Wi-Fi enabled - connects with the SmarthQ™ app for seamless control

DIMENSIONS

Height	850mm
Width	600mm
Depth	665mm

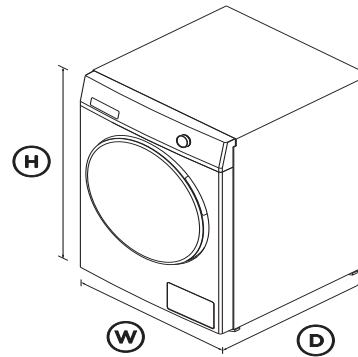

FEATURES & BENEFITS

Ultimate Fabric Care Solutions

Care for every corner of the wardrobe with an ecosystem of fabric care products, including our Front Loader Washing Machine, Heat Pump Dryer, and Fabric Care Cabinet. From

precision sensing to autonomous technologies, the fabric care suite removes the guesswork, delivering the perfect balance across each product to ensure optimal care for every garment.

Care for every fabric

With 29+ fabric care cycles including Activewear, Denim, Silk and Sanitise. The specially-designed cushioned drum provides a gentle, effective washing action, protecting clothes while delivering an optimal wash performance.

Refresh, revive, respect

Ideal for lightly-worn garments, our 20-minute Steam Refresh Cycle leaves clothes fresh, wrinkle free and ready to wear in minutes. By using Steam Refresh, you can save up to 92% of water compared to a Quick 30 wash cycle.

Remove the guesswork

Every wash is unique with ActiveIntelligence™ autosensing. Intelligent sensors determine load size and soil level before automatically dispensing just the right amount of detergent and adjusting the wash time, for over 1200 possible wash combinations. Available on Cotton, Heavy, Mixed, Delicate and Sports cycles.

A Connected Solution

Choose from 29+ fabric care cycles with real-time updates and helpful prompts, thanks to the intuitive touchscreen display and push-to-select dial. Integrate your laundry system to seamlessly program and manage both your washing machine and our display-free heat pump dryer from a single point of control.

5 star energy and water

This washing machine uses intelligent sensing, sophisticated wash cycles and an enhanced water recirculation system to gently and effectively wash clothes. With a 5 star energy and 5 star water rating, you can clean with confidence.

Designed To Match

Our Steam Care washing machine is designed to match our Heat Pump Dryer and Fabric Care Cabinet, giving you the design freedom to create a cohesive fabric care ecosystem. With multiple configurations from compact to large, this modular

solution is designed to work for many spaces within the architecture of the evolving home.

SPECIFICATIONS

Consumption

Energy rating	5 star
Energy usage	286kWh/year
In-use energy carbon	186.3kgCO2e/year
Water efficiency	5 star (WELS)

Controls

Adjustable audio and display	•
Control type	Dial with illuminated halo
Electronic clock	•
Intuitive touchscreen display	•
Screen brightness settings	•

Features

Add a garment (immediate)	•
Adjustable alert beeps	•
Anti-fungal door gasket	•
Auto out of balance correction	•
Automatic water level	•
Child/Keylock	•
Delay start	•
Detergent dispenser	•
Enabled for downloadable	•
Fabric softener dispenser	•
Flood protection	•
Interior light	•

Optimize wash	Quiet, Speed, Eco
Pre Wash	•
Progress indicator	•
Quiet mode	•
Rinse +	•
Soak	•
Speed mode	•
Spin speeds	5
Stainless steel drum	•
Time to go	•
Water supply	Hot & Cold
Wi-Fi capable	•
Woolmark certified	•
Wrinkle Free	•

Performance

ActiveIntelligence™ technology	•
Auto soil sensing	•
Auto-dose	•
Load sensing	•
Maximum spin speed	1400rpm
Smart Diagnosis of problems	•
SmartDrive™ technology	•
Spin performance	No spin, 500, 800, 1100, 1400
Steam Care	•
Vortex Wash	•

Product dimensions

Depth	665mm
-------	--------------

Height	850mm
Width	600mm

Warranty

Parts and labour	2 years
Parts only SmartDrive™ Motor	10 years

Wash By Sensing

Cotton	•
Delicate	•
Heavy	•
Mixed	•
Number of cycles	5
Sports	•

Wash Cycles

Activewear	•
Allergy	•
Bulky	•
Cottons	•
Delicate	•
Denim	•
Drum Clean	•
Easy Iron	•
Handwash	•
Heavy	•
Mixed	•
Number of wash cycles	24
Quick 15	•
Quick 30	•

- Rinse •
- Sanitise •
- Sheets •
- Silk •
- Sneakers •
- Soft toys •
- Spin •
- Sports •
- Steam Refresh •
- Synthetics •
- Towels •
- Wool •

SKU 92297

Other product downloads available at fisherpaykel.com

- [↓](#) Service & Warranty
- [↓](#) Energy & Water Label Front Loader Washing Machine
- [↓](#) User Guide Front Loader Washing Machine
- [↓](#) User Guide Fabric Care Solutions Multi-Product Setup
- [↓](#) Stacked Installation Guide Fabric Care Solutions
- [↓](#) Installation Guide Front Loader Washing Machine
- [↓](#) Installation Guide - Washer on Plinth
- [↓](#) Side-by-Side Multiple Product Installation on Plinths
- [↓](#) Planning Guide Fabric Care Solutions

The product dimensions and specifications in this page apply to the specific product and model. Under our policy of continuous improvement, these dimensions and specifications may change at any time. You should therefore check with Fisher & Paykel's Customer Care Centre to ensure this page correctly describes the model currently available. Fisher & Paykel Appliances Ltd 2020

Where applicable:

All appliances use energy, and energy usage typically generates carbon emissions. **Fisher & Paykel Appliances' In-use Energy Carbon Emissions Estimate** indicates carbon emissions from a product's in-use energy. This is calculated either annually or per cycle, using the product's market-specific energy label energy consumption data multiplied by the carbon emissions factor for energy in your country or region.

Our In-use Energy Carbon Emissions Estimate is designed to assist customers in making informed purchasing decisions when comparing different Fisher & Paykel products. For example, a heat pump dryer typically has a lower In-use Energy Carbon Emissions Estimate than a vented dryer.



A PEACE OF MIND SALE

24 Hours 7 Days a Week Customer Support

T 1300 650 590 Wwww.fisherpaykel.com