

24" Series 5 Contemporary Self-Cleaning Oven, 7 Function

Contemporary



With generous capacity and beautiful contemporary styling, this built-in oven will complement your kitchen design perfectly.

- Three cubic feet total capacity, with seven oven functions including Aero™ Pastry
- Self-cleaning function breaks down food residue for an easy clean
- Moisture control and even heat distribution thanks to ActiveVent™ and AeroTech™ technology
- Optional non-tip, full-extension sliding shelves for safe removal of hot dishes

DIMENSIONS

Height	23 9/16 "
Width	23 1/2 "
Depth	22 1/4 "

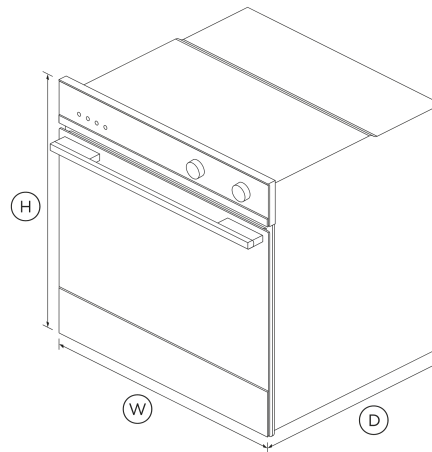

FEATURES & BENEFITS

Generous Capacity

With a generous sized internal cavity, you can create several dishes at once using multiple shelves.

Perfect Results

Our built-in ovens feature ActiveVent technology for optimized moisture levels, and AeroTech™ for even heat distribution. Get perfect results even when you're using multiple shelves.

Multi-Function Flexibility

Seven functions including Aero™ Pastry, Aero™ Bake and True Aero™ mean no matter what you're cooking, you've got the right heat to match.

Seamless Fit

Designed to fit seamlessly in your kitchen, this built-in oven fits flush with cabinetry to minimize gaps and add to a cohesive aesthetic.

Cleaning Is Simple

The self-clean function breaks down food residue at a very high temperature, leaving a light ash that's easily removed with a damp cloth.

Refined Styling

With sophisticated handle styling and stainless steel finish, our built-in ovens are designed to match the rest of Fisher & Paykel's kitchen appliance family.

Safe And Sound

The CoolTouch door features triple glazing and a cooling system that ensures it's safe to touch from the outside - protecting both your hands and the surrounding cabinetry.

SPECIFICATIONS

Accessories (included)

Grill pan	1
Step down wire shelf	1
Wired temperature sensor	1

Accessories (sold separately)

Optional Accessory round handle	Part 81671
Optional round handle	Part 81645

Capacity	
Shelf positions	6
Total capacity	3 cu ft
Usable capacity	2.5 cu ft

Cleaning	
Acid resistant graphite enamel	•
Pyrolytic self-clean	•
Removable oven door	•
Removable oven door inner glass	•
Removable side ladders	•

Controls	
Audio feedback	•
Automatic cooking/minute timer	•
Automatic pre-set temperatures	•
Celsius/Fahrenheit temperature	•
Electronic capacitive touch controls	•
Electronic clock	•
Electronic oven control	•
Intuitive touchscreen display	•
Soft close doors	•

Functions	
Aero Broil	•
Aero Pastry	•
Aero™ Bake	•
Bake	•

Broil	•
Maxi Broil	•
Number of functions	7
Pyrolytic self-clean	•
Rapid proof	•
Roast	•
True Aero	•
Vent bake	•
Warm	•

Performance	
ActiveVent™ system	•
AeroTech™ technology	•
Automatic rapid pre-heat	•
Broil power	3200 W
Whisper Quiet Cooking	•

Power Requirements	
Amperage	16.6-19.4 A
Supply frequency	60 Hz
Supply voltage	208 - 240 V

Product Dimensions	
Depth	22 1/4 "
Height	23 9/16 "
Width	23 1/2 "

Safety

•	ADA compliant	•
•	Balanced oven door	•
•	Catalytic venting system	•
•	Control panel key lock	•
•	Non-tip shelves	•

SKU 82258

The product dimensions and specifications in this page apply to the specific product and model. Under our policy of continuous improvement, these dimensions and specifications may change at any time. You should therefore check with Fisher & Paykel's Customer Care Centre to ensure this page correctly describes the model currently available. © Fisher & Paykel Appliances Ltd 2020

Other product downloads available at fisherpaykel.com

- [↓](#) DWG
- [↓](#) DXF
- [↓](#) Data Sheet (English)
- [↓](#) Installation Guide (English, Canadian French)
- [↓](#) Right To Repair Declaration (English, Canadian French)
- [↓](#) User Guide (English)
- [↓](#) User Guide (English)

Where applicable:

All appliances use energy, and energy usage typically generates carbon emissions. **Fisher & Paykel Appliances' In-use Energy Carbon Emissions Estimate** indicates carbon emissions from a product's in-use energy. This is calculated either annually or per cycle, using the product's market-specific energy label energy consumption data multiplied by the carbon emissions factor for energy in your country or region.

Our In-use Energy Carbon Emissions Estimate is designed to assist customers in making informed purchasing decisions when comparing different Fisher & Paykel products. For example, a heat pump dryer typically has a lower In-use Energy Carbon Emissions Estimate than a vented dryer.



A PEACE OF MIND SALE
24 Hours 7 Days a Week Customer Support
T 1.888.936.7872 W www.fisherpaykel.com