

# Dual Fuel Range, 48", 5 Burners with Griddle, Self-cleaning, LPG

Series 9 | Professional

Stainless Steel | LPG



With intuitive touchscreen and specialized cooking functions across two ovens, this range is a stand-out addition to your kitchen.

- Guided cooking using your touchscreen makes it simple to cook by food, function or recipe.
- Gas cooktop with a griddle and five burners that deliver up to 19,000 BTU for fast boiling
- 6.9 cu ft total oven capacity across two oven cavities

- Beautiful LED halo-illuminated dials provide information at a glance

## DIMENSIONS

Height	35 3/4 - 36 3/4"
Width	47 7/8"
Depth	29 1/8"

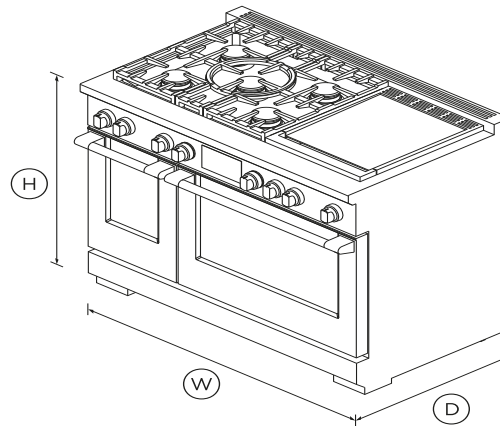

## FEATURES & BENEFITS

### Cook with confidence

Our touchscreen interface provides an intuitive guided cooking experience that helps deliver perfect results, whether you've been cooking all your life or just starting out. Cook with a favorite method, a hero ingredient, or a go-to cooking function or recipe. The screen tilts for improved ergonomics and optimal

visibility while cooking.

### Generous capacity

Two independently operating cavities provide a large total capacity of 4.8 cu. ft. in the main cavity and 2.1 cu. ft. in the secondary. That's enough room for a 32 lb turkey in one oven, and your sides in the other.

### Cooking flexibility

No matter what you're cooking, you've got the right heat to get perfect results. Each of the 15 oven functions in the main cavity and 11 in the secondary have been extensively researched and carefully designed to cater to a broad range of dishes and cooking styles. The handy food probe helps you monitor your progress.

### Cooktop power

Sealed dual flow burners deliver cooktop power up to 19,000 BTU for seriously fast boiling, and precise 140°F full surface, low temperature cooking with the gentlest of flames.

### Design quality

This range has craftsmanship in every detail, with real stainless steel, cast-iron trivets, and beautifully weighted, halo illuminated dials. Each cavity features incandescent lights and full extension telescopic racks. From the robust legs to the powerful cooktop, this Range is built to last.

### Easy to clean

The oven features a self-cleaning function and self-clean proof side racks, which don't need to be removed when using this function.

## SPECIFICATIONS

### Accessories

Square handle option

AH-R48

### Capacity

Capacity total (AHAM)	<b>4.8cu ft</b>
Capacity usable (AHAM)	<b>3.8cu ft</b>
Shelf positions	<b>5</b>
Total capacity	<b>6.9cu ft</b>
Total capacity second oven	<b>2.1cu ft</b>

**Cleaning**

Dishwasher proof trivets	•
Pyrolytic self-clean	•

**Controls**

Dial with illuminated halo	•
Electric circuit	<b>4 wire</b>
High resolution display	•
Metal illuminated dials	•
Multi-language interface	•
Precise cooking with food	•
Recipe and food based	•
Sabbath mode	•
Tilting touch screen interface	•
Wifi connectivity	•

**Gas Requirements**

Fitting and pipe	<b>½ NPT, min. 5/8" flex line</b>
Supply Pressure (LPG)	<b>11" to 14" W.C</b>
Supply Pressure (natural gas)	<b>6" to 9" W.C</b>

**Installation Dimensions**

Height (excluding vent trim)	<b>35 3/4 - 36 3/4"</b>
------------------------------	-------------------------

**Oven features**

Concealed element	•
Electronic oven control	•
Full extension telescopic	•
Internal light	•
Titanium coated, illuminated	•

**Oven functions**

Warm	•
------	---

**Oven performance**

Bake	•
Bake	<b>4600 BTU</b>
Bake power	<b>4600</b>
Broil	<b>3600W</b>
Main oven - True convection	<b>2500W</b>

**Power requirements**

Amperage	<b>50A</b>
Rated current	<b>50A</b>
Supply frequency	<b>60Hz</b>

**Product dimensions**

Depth	<b>29 1/8"</b>
Height	<b>35 3/4 - 36 3/4"</b>
Width	<b>47 7/8"</b>

**Rangetop features**

Sealed Dual Flow Burners™	<b>5</b>
---------------------------	----------

Sealed range top	•
Vent trim included	•

**Rangetop Performance**

Max burner power	<b>19,000 BTU</b>
Power back left	<b>11,500 BTU</b>
Power back right	<b>11,500 BTU</b>
Power centre	<b>19,000 BTU</b>
Power front left	<b>15,000 BTU</b>
Power front right	<b>15,000 BTU</b>
Power griddle	<b>24,000 BTU</b>
Total cooktop power	<b>96,000 BTU</b>

**Recommended Back Guards Ventilation**

Combustible situation	<b>BGRV3-3048H</b>
Non combustible situation	<b>BGRV2-3048 / BGRV2-1248</b>
Recommended hood	<b>HCB48-12_N (48"")</b>

**Safety**

ADA compliant	•
---------------	---

**Secondary oven features**

3/4 Extension racks	<b>2</b>
Concealed element	•
Convection bake	•
Electronic oven control	•
Food probe	•
Internal light	•

**Secondary oven functions**

- Air fry •
- Bake •
- Classic bake •
- Convection broil •
- Maxi broil •
- Number of secondary oven 11
- Pastry bake •
- Pizza bake •
- Rapid proof •
- Roast •
- Warm •

---

SKU 81895

---

TEST The product dimensions and specifications in this page apply to the specific product and model. Under our policy of continuous improvement, these dimensions and specifications may change at any time. You should therefore check with Fisher & Paykel's Customer Care Centre to ensure this page correctly describes the model currently available. ? Fisher & Paykel Appliances Ltd 2020

---

**Other product downloads available at fisherpaykel.com**

- [↓](#) User Guide
- [↓](#) User Guide
- [↓](#) User Guide
- [↓](#) Guide D'Utilisation
- [↓](#) Installation Guide
- [↓](#) Installation Guide
- [↓](#) Installation Guide
- [↓](#) Guide D'Installation
- [↓](#) Specification Guide Dual Fuel Range
- [↓](#) Data Sheet Dual Fuel Range
- [↓](#) Planning Guide Dual Fuel Range



**A PEACE OF MIND SALE**

24 Hours 7 Days a Week Customer Support

T 1.888.936.7872 **W**www.fisherpaykel.com