

# FISHER & PAYKEL

## PRELIMINARY SPECIFICATION GUIDE

## MICROWAVE OVEN, 60CM



### OVERVIEW

With timeless Contemporary styling, the Combination Microwave Oven is designed to fit seamlessly into any kitchen. A flexible appliance that pairs the speed of microwave cooking with oven technology, which can crisp and brown as it cooks. Featuring 22 cooking functions on an intuitive touch display for easy programming of desired cooking mode and duration. A Wired Temperature Sensor monitors cooking in real time for complete control.

\*Selected markets and models

### MODELS

#### Combination Microwave Oven, 60cm

Stainless Steel, Touchscreen, Dial  
OM60NDTDX1

### SERIES & STYLE

Series 9  
Contemporary

### ACCESSORIES

- 1 Wire Shelves
- 2 Microwave glass dish
- 3 Wired Temperature Sensor

### FEATURES

- 1 Contemporary style, designed to fit flush with cabinetry
- 2 Compact size for smaller kitchens, and generous 49L capacity with 4 shelf positions to cook for everyday's needs
- 3 Intuitive, large 5" touchscreen display with illuminated dial
- 4 The benefits of both microwave and convection oven cooking in one
- 5 22 cooking functions, including 14 traditional convection functions, 4 microwave-only functions, and 4 microwave combination functions
- 6 Guided touchscreen cooking makes it simple to cook by food and function
- 7 Wired Temperature Sensor precisely monitors cooking in real time\*
- 8 Inverter technology for fast and even heating, and quiet product operation
- 9 Wi-Fi/Connected capability through the SmartHQ™ app\*

\*Selected markets and models

# FISHER & PAYKEL

## PRELIMINARY SPECIFICATION GUIDE

## MICROWAVE OVEN, 60CM

### SPECIFICATIONS

Model No.	OM60NDTDX1
Dimensions	H 458mm W 596mm D 565mm
Total capacity	49L
Weight	38 kg (unpackaged) 46 kg (packaged)
Electrical	
Supply	220-240VAC, 50Hz
Service	max 20A circuit

### PRODUCT DIMENSIONS

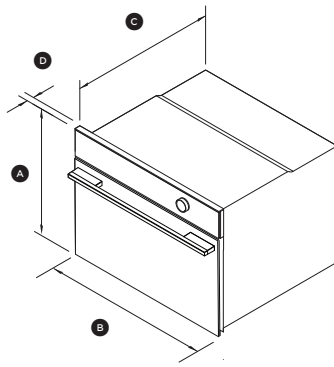

ISO VIEW

	mm
(A) Overall height	458
(B) Overall width	596
(C) Depth of chassis	545
(D) Depth from front frame (excludes dial and handle)	20
Depth of oven door when fully open (measured from front of control panel)	320

### CAVITY DIMENSIONS

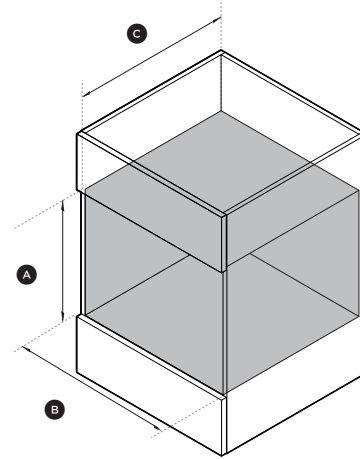

ISO VIEW

	mm
(A) Minimum inside height	440
(B) Minimum inside width	560
(C) Minimum inside depth	550