

# Double DishDrawer™ Dishwasher

Series 7 | Contemporary

Stainless Steel



Wash one drawer while you load the other, with minimal bending and room in each drawer for full-size dinner plates.

- Six wash programs to suit any load, from Delicate to Heavy
- Flexible racking allows you to customise internal shelves to suit your needs

## DIMENSIONS

Height	820 - 880mm
Width	599mm
Depth	573mm

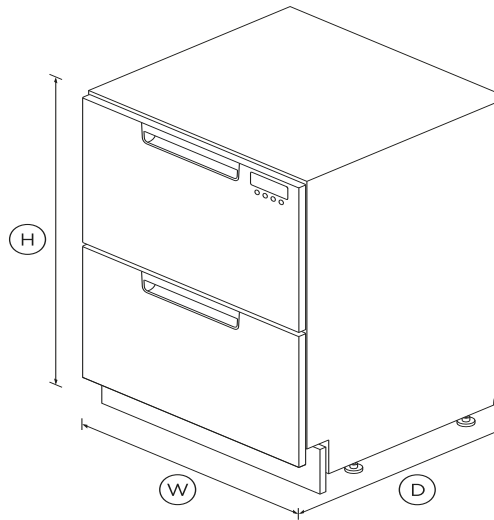

## FEATURES & BENEFITS

### Ease of use

DishDrawer™ Dishwashers are as easy to open and close as kitchen drawers and can be conveniently positioned at bench height for ease of loading and minimal bending.

### Independent wash

With the ability to use both drawers independently and select different wash programs, the DishDrawer™ Dishwasher can wash everything from fine glass and crystal to heavily soiled pots and pans.

### True half load

Each drawer holds a true half load for small washes and fast turnaround of your dishes. Both drawers operate independently so different wash cycles can run simultaneously to accommodate a variety of loads.

### Seamless integration

DishDrawer™ Dishwashers are designed to match the Fisher & Paykel family of kitchen appliances, with matching handles, premium styling and quality materials for a stylish finish in your kitchen.

### Quick, Sanitize and Extra Dry

The Quick wash modifier delivers a faster wash while maintaining performance. The Sanitize option provides extra protection killing 99.9% of bacteria in the final rinse. The Extra Dry setting is perfect for plastic dishes.

### Quiet performer

Running at a very low decibel rating, these DishDrawer™ Dishwashers do their job without making a fuss. The combination of intelligent technology and simple mechanics means greater reliability and excellent wash performance.

## SPECIFICATIONS

### Accessories

- Cutlery basket
- Kickstrip

### Capacity and loading

Accommodates round plates	280mm
Fixed height, foldable cupracks	•
Fold down tines	•
Place settings	14
Place settings per drawer	7

**Consumption**

Energy rating	<b>3.5 star</b>
Energy usage	<b>136kWh/year</b>
Water consumption (per wash)	<b>6.9L</b>
Water efficiency	<b>4.5 star (WELS)</b>

**Controls**

Electronic fault/Diagnostic	•
End of cycle beeps	•
Energy saving delay start	•
Keylock	•
Rinse aid indicator light	•
Wi-Fi connectivity	•

**Features**

Fan assisted drying	•
Flood protection	•
Flow through detergent	•
Motor type	<b>BLDC</b>
Quiet operation	•
SmartDrive™ technology	•

**Performance**

Noise on standard cycle top	<b>43dBA</b>
-----------------------------	--------------

**Power requirements**

Amperage	<b>10A</b>
Supply frequency	<b>50Hz</b>
Supply voltage	<b>220 - 240V</b>

**Product dimensions**

Depth	<b>573mm</b>
Height	<b>820 - 880mm</b>
Width	<b>599mm</b>

**Warranty**

Parts and labour	<b>2 years</b>
------------------	----------------

**Wash Programs**

Delicate	•
Eco	•
Fast	•
Heavy	•
Medium	•
Rinse	•
Wash programs	<b>6</b>

**Water connection**

Water pressure	<b>30kPa - 1000 kPa</b>
Water supply	<b>3/4" BSP (20mm) Connector</b>

SKU	<b>82310</b>
-----	--------------

The product dimensions and specifications in this page apply to the specific product and model. Under our policy of continuous improvement, these dimensions and specifications may change at any time. You should therefore check with Fisher & Paykel's Customer Care Centre to ensure this page correctly describes the model currently available. © Fisher & Paykel Appliances Ltd 2020

**Other product downloads available at fisherpaykel.com**

- [↓](#) Service & Warranty
- [↓](#) User Guide DishDrawer™ Dishwasher
- [↓](#) Wash Program Data ASNZS DishDrawer™ Dishwasher
- [↓](#) Energy & Water Label DishDrawer™
- [↓](#) Installation Guide Double DishDrawer™ Dishwasher
- [↓](#) Installation Guide Double DishDrawer™ Dishwasher

**A PEACE OF MIND SALE****24 Hours 7 Days a Week Customer Support****T 1300 650 590 W www.fisherpaykel.com**