

12kg Series 11 Front Loader Washer, ActiveIntelligence, Steam Care



Care for every corner of the wardrobe with a Wi-Fi-enabled fabric care ecosystem. With 29+ cycles, this Steam Care washer combines with our Heat Pump Dryer and Fabric Care Cabinet to create an ultimate fabric care solution.

- Combine with a Heat Pump Dryer and Fabric Care Cabinet to create an ultimate fabric care ecosystem
- Centralised control – the intuitive touchscreen display can also control a display-free heat pump dryer*
- Refresh, revive and dewrinkle garments using the 20 minute Steam Refresh cycle

- Wi-Fi enabled – connects with the Haier Smart Home app for remote control, notifications, scheduled starts, voice commands and more

DIMENSIONS

Height	850 mm
Width	600 mm
Depth	665 mm

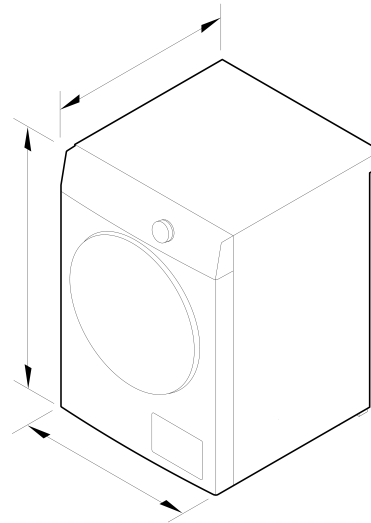

FEATURES & BENEFITS

Ultimate Fabric Care Solutions

Care for every corner of the wardrobe with an ecosystem of fabric care products, including our Front Loader Washing Machine, Heat Pump Dryer, and Fabric Care Cabinet. From precision sensing to autonomous technologies, the fabric care suite removes the guesswork, delivering the perfect balance across each product to ensure optimal care for every garment.

Care For Every Fabric

With 29+ fabric care cycles including Activewear, Denim, Silk and Sanitise. The specially-designed cushioned drum provides a gentle, effective washing action, protecting clothes while delivering an optimal wash performance.

Refresh, Revive, Respect

Ideal for lightly-worn garments, our 20-minute Steam Refresh Cycle leaves clothes fresh, wrinkle free and ready to wear in minutes. By using Steam Refresh, you can save up to 92% of water compared to a Quick 30 wash cycle.

Remove The Guesswork

Every wash is unique with ActiveIntelligence™ autosensing. Intelligent sensors determine load size and soil level before automatically dispensing just the right amount of detergent and adjusting the wash time, for over 1200 possible wash combinations. Available on Cotton, Heavy, Mixed, Delicate and Sports cycles.

A Connected Solution

Choose from 29+ fabric care cycles with real-time updates and helpful prompts, thanks to the intuitive touchscreen display and push-to-select dial. Integrate your laundry system to seamlessly program and manage both your washing machine and our display-free heat pump dryer from a single point of control.

5 Star Energy And Water

This washing machine uses intelligent sensing, sophisticated wash cycles and an enhanced water recirculation system to gently and effectively wash clothes. With a 5 star energy and 5 star water rating, you can clean with confidence.

Designed To Match

Our Steam Care washing machine is designed to match our Heat Pump Dryer and Fabric Care Cabinet, giving you the design freedom to create a cohesive fabric care ecosystem. With multiple configurations from compact to large, this modular solution is designed to work for many spaces within the architecture of the evolving home.

SPECIFICATIONS

Capacity

Capacity **12 kg**

Consumption

Energy rating **Grade 1**

Controls

- Adjustable audio and display settings •
- Control type **Dial with illuminated halo**
- Electronic clock •
- Intuitive touchscreen display •
- Screen brightness settings •

Features

- Add a garment (immediate door opening) •

- Adjustable alert beeps •
- Anti-fungal door gasket •
- Auto out of balance correction •
- Automatic water level •
- Child/Keylock •
- Delay start •
- Detergent dispenser **Manual**
- Enabled for downloadable cycles •
- Fabric softener dispenser **Manual**
- Flood protection •
- Interior light •
- Optimize Wash **Quiet, Speed, Eco**
- Pre Wash •
- Progress indicator •
- Quiet mode •
- Rinse + •
- Soak •
- Speed mode •
- Spin speeds **5**
- Stainless steel drum •
- Time to go •
- Water supply **Hot & Cold**
- Wi-Fi capable •
- Woolmark certified •
- Wrinkle Free •

Performance

- ActiveIntelligence™ technology •
- Auto load sensing •
- Auto soil sensing •

- Auto-dose •
- Maximum spin speed **1400 rpm**
- Smart Diagnosis of problems •
- SmartDrive™ technology •
- Spin performance **No spin, 500, 800, 1100, 1400**
- Steam Care •
- Vortex wash •

Product dimensions

Depth **665 mm**
 Height **850 mm**
 Width **600 mm**

Wash By Sensing

- Cotton •
- Delicate •
- Heavy •
- Mixed •
- Number of cycles **5**
- Sports •

Wash Cycles

- Activewear •
- Allergy •
- Bulky •
- Cottons •
- Delicate •
- Denim •

Drum Clean	•
Easy Iron	•
Handwash	•
Heavy	•
Mixed	•
Number of wash cycles	24
Quick 15	•
Quick 30	•
Rinse	•
Sanitise	•
Sheets	•
Silk	•
sneakers	•
Soft toys	•
Spin	•
Sports	•
Steam Refresh	•
Synthetics	•
Towels	•
Wool	•

Other product downloads available at fisherpaykel.com

- [↓](#) DWG
- [↓](#) DXF
- [↓](#) Energy Label
- [↓](#) Installation Guide - Side by Side (English)
- [↓](#) Installation Guide - Stacked (English)
- [↓](#) Installation Guide (English)
- [↓](#) Installation Guide - Washer on Plinth (English)
- [↓](#) Installation Guide - Side by Side (Chinese)
- [↓](#) Installation Guide - Stacked (Chinese)
- [↓](#) Installation Guide (Chinese)
- [↓](#) Installation Guide - Washer on Plinth (Chinese)
- [↓](#) Planning Guide (English)
- [↓](#) Planning Guide (Chinese)
- [↓](#) Revit
- [↓](#) Rhino
- [↓](#) SketchUp
- [↓](#) User Guide - Multi-Product Setup (English)
- [↓](#) User Guide (English)
- [↓](#) User Guide - Multi-Product Setup (Chinese)
- [↓](#) User Guide (Chinese)

Our In-use Energy Carbon Emissions Estimate is designed to assist customers in making informed purchasing decisions when comparing different Fisher & Paykel products. For example, a heat pump dryer typically has a lower In-use Energy Carbon Emissions Estimate than a vented dryer.

SKU 95221

Where applicable:

All appliances use energy, and energy usage typically generates carbon emissions. **Fisher & Paykel Appliances' In-use Energy Carbon Emissions Estimate** indicates carbon emissions from a product's in-use energy. This is calculated either annually or per cycle, using the product's market-specific energy label energy consumption data multiplied by the carbon emissions factor for energy in your country or region.

The product dimensions and specifications in this page apply to the specific product and model. Under our policy of continuous improvement, these dimensions and specifications may change at any time. You should therefore check with Fisher & Paykel's Customer Care Centre to ensure this page correctly describes the model currently available. © Fisher & Paykel Appliances Ltd 2020