

12kg Series 9 Front Loader Washer, ActiveIntelligence

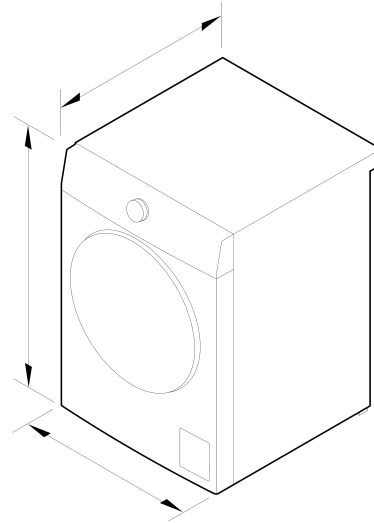

Height	850 mm
Width	600 mm
Depth	665 mm



Our Hygiene cycles including Allergy and Sanitise provide extra protection for your clothes. The higher wash temperature and an extra rinse cycle is designed to kill more than 99.9% of bacteria and reduce allergens.

Activeintelligence™ Auto-Sensing

Every wash is unique with ActiveIntelligence™ technology. Intelligent sensors determine load size and soil level before dispensing just the right amount of detergent and adjusting the wash time, for over 1200 possible wash combinations. Available on Cotton, Heavy, Everyday, Delicate and Sports cycles.

Less Waste With Auto Dose

Prolong the life of your garments with Auto Dose mode. Auto Dose dispenses the exact amount of liquid detergent required based on load size - resulting in less waste, less hassle and less detergent residue, with the added convenience of not needing to fill the dispenser for every wash.

Customise Your Wash

Shorten your total wash time with our Speed option, or choose Eco to wash more sustainably. The Quiet mode reduces cycle noise, perfect for late night washing without waking the house.

Time Saving

When time is short you can select a quick 15 minute wash for freshening up new or lightly soiled garments. In fact, Vortex Wash allows most cycles to take less than one hour to complete. Water is forced from the bottom of the drum, so detergent and heat reach your clothes faster, cleaning quickly and avoiding over-washing.

FEATURES & BENEFITS

The Pinnacle Of Fabric Care

Easy to use, the LCD display provides a simple interface to select from 26 fabric care cycles; including Denim, Handwash and Wool, to deliver an optimal wash performance.

Refresh, Revive, Respect

Bring lightly worn clothes, musty stored garments and even soft furnishings back to life with Steam Refresh. The 20 minute cycle removes odours so clothes can be worn again without the need for a full wash cycle, while steam reduces creases to save you precious time spent ironing.

Health And Hygiene

This Steam Care front loader has 25 different fabric care cycles, with an excellent Class 1 energy rating

- Refresh, revive and dewrinkle garments using the 20 minute Steam Refresh cycle
- ActiveIntelligence™ removes the guesswork by tailoring detergent dose and adjusting wash times to suit each load
- Save time, minimise noise and reduce water usage with Optimise Wash options
- Select from 25 fabric care cycles using intuitive LCD display

DIMENSIONS

SPECIFICATIONS

Capacity

Capacity

12 kg

Consumption

Water consumption per cycle **70L**

Water temperature controls **5**
 Woolmark certified •
 Wrinkle Free •

Delicate •

Denim •

Drum Clean •

Handwash •

Heavy •

Mixed •

Features

Add a garment (immediate door opening) •

Adjustable alert beeps •

Anti-fungal door gasket •

Auto out of balance correction •

Automatic water level •

Child/Keylock •

Delay start •

Detergent dispenser **Manual**

Excess foam detection •

Fabric softener dispenser **Manual**

Flood protection •

Hot and cold water inlets •

Interior light •

Intuitive LCD screen •

Pre Wash •

Progress indicator •

Quiet mode •

Rinse + •

SmartTouch™ control dial •

Soak •

Speed mode •

Spin speeds **5**

Stainless steel drum •

Time to go •

Wash + •

Water supply **Hot & Cold**

Performance

ActiveIntelligence™ technology •

Auto load sensing •

Auto soil sensing •

Auto-dose •

Maximum spin speed **1400 rpm**

Noise rating (spin) **A**

Number of spin speeds **5**

SmartDrive™ technology •

Spin performance **C**

Steam Care •

Vortex wash •

Number of wash cycles **26**

Quick 15 •

Quick 30 •

Rinse •

Sanitise •

Sheets •

Silk •

sneakers •

Soft toys •

Spin •

Sports •

Steam Refresh •

Synthetics •

Towels •

Wool •

Product dimensions

Depth **665 mm**

Height **850 mm**

Width **600 mm**

SKU **93287**

Wash Cycles

20°C •

Activewear •

Allergy •

Bulky •

Cottons •

The product dimensions and specifications in this page apply to the specific product and model. Under our policy of continuous improvement, these dimensions and specifications may change at any time. You should therefore check with Fisher & Paykel's Customer Care Centre to ensure this page correctly describes the model currently available. © Fisher & Paykel Appliances Ltd 2020

Other product downloads available at fisherpaykel.com

- [↓](#) Energy Label
- [↓](#) Installation Guide (English)
- [↓](#) Installation Guide (Chinese)
- [↓](#) User Guide (English)
- [↓](#) User Guide (Chinese)

Where applicable:

All appliances use energy, and energy usage typically generates carbon emissions. **Fisher & Paykel Appliances' In-use Energy Carbon Emissions Estimate** indicates carbon emissions from a product's in-use energy. This is calculated either annually or per cycle, using the product's market-specific energy label energy consumption data multiplied by the carbon emissions factor for energy in your country or region.

Our In-use Energy Carbon Emissions Estimate is designed to assist customers in making informed purchasing decisions when comparing different Fisher & Paykel products. For example, a heat pump dryer typically has a lower In-use Energy Carbon Emissions Estimate than a vented dryer.