

17.5 cu ft Series 5 Refrigerator Freezer

Width 31 1/8 "

Depth 27 3/8 "

Contemporary



This stylish left hinge refrigerator comes in timeless stainless steel with concealed handles for a more streamlined look.

- Ultra flat door conceals handles for streamlined look
- Bottom freezer
- ActiveSmart™ helps keep food fresher for longer

DIMENSIONS

Height 67 3/4 "

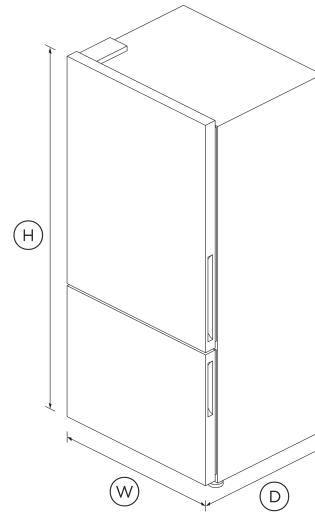

FEATURES & BENEFITS

ActiveSmart™ Foodcare

Every time you open your refrigerator, the temperature around your food changes. ActiveSmart™ foodcare adjusts airflow to create a stable temperature, helping your food stay fresher for longer.

Clever Energy

Your refrigerator adapts to daily use by cooling and defrosting only when needed. This means your refrigerator uses the energy it needs without compromising on food care.

Humidity Control

Your fruit and veges need different environments. The humidity control slides in each storage bin create a microclimate that helps keep food fresher for longer.

Easy Cleaning

No more permanent dirty marks with our EZKleen feature for stainless steel refrigerators. Anti-fingerprint coating means you simply wipe clean any marks. Spill-safe secure glass shelves easily capture any drips or leaks.

Design Quality

Our refrigerators are designed and built using quality materials. We use real stainless steel on our refrigerators and solid glass for shelving.

SPECIFICATIONS

Accessories (sold separately)

Matching Replacement Water Filter Model **N/A**

Capacity

Total gross capacity	17.5 cu ft
Volume	17.5 cu ft
Volume freezer	5.2 cu ft
Volume refrigerator	12.3 cu ft

Connected Features

- Alerts and notifications
- Education and onboarding
- Remote operation
- Software updates

Consumption

Energy rating **Energy Star**

Energy usage	454kWh/year
In-use energy carbon emissions estimate	52.3kgCO₂e/year

Slide Out Pastry Tray	•
Small plastic bins	•

Certifications and Listings	N/A
Country of Origin	Thailand (TH)

Controls

Control Type	Electronic
--------------	-------------------

Performance

ActiveSmart™ Foodcare	•
Adaptive defrost	•
Frost free	•
Frost free freezer	•
Humidity control system	•
Humidity controlled crisper bins	2
Inverter controlled compressor	•
Sabbath mode	•

Variable Temp Compartment

Bottle chill mode	•
-------------------	---

Features

Adjustable door shelves	6
Adjustable glass shelves	4
Covered door shelves	2
Door alarm	•
Front levelling feet	•
Fruit and vegetable bins	2
Gallon door shelves	1
Keylock	•
LED lighting	•
Rear rollers	•
Smart appliance	•
SmartTouch control panel	•
Stackable bottle holders	2

Power requirements

Rated current	10 A
Supply frequency	60 Hz
Supply voltage	115 V

SKU	26287
-----	--------------

The product dimensions and specifications in this page apply to the specific product and model. Under our policy of continuous improvement, these dimensions and specifications may change at any time. You should therefore check with Fisher & Paykel's Customer Care Centre to ensure this page correctly describes the model currently available. © Fisher & Paykel Appliances Ltd 2020

Other product downloads available at fisherpaykel.com

- [↓](#) DXF
- [↓](#) Data Sheet (English)
- [↓](#) DWG
- [↓](#) Energy Label
- [↓](#) Installation Guide (English)
- [↓](#) Installation Guide (English)
- [↓](#) Installation Guide (English)
- [↓](#) Water Filter Replacement Instructions - Parts 847200 and 847201 (French)
- [↓](#) Installation Guide - Joiner Kit (Canadian French)
- [↓](#) Installation Guide (Canadian French)
- [↓](#) Right To Repair Declaration (English, Canadian French)
- [↓](#) User Guide (English)
- [↓](#) User Guide (Canadian French)

Freezer Features

Bottle chill	•
Door alarm	•
Fast freeze	•
Freezer bins	4
Freezer drawers	4
Large plastic bins	•

Product dimensions

Depth	27 3/8 "
Height	67 3/4 "
Minimum air clearance at rear	1 3/16 "
Minimum air clearance each side	1 3/16 "
Minimum air clearance on top	2 "
Width	31 1/8 "

Product information

Where applicable:

All appliances use energy, and energy usage typically generates carbon emissions. **Fisher & Paykel Appliances' In-use Energy Carbon Emissions Estimate** indicates carbon emissions from a product's in-use energy. This is calculated either annually or per cycle, using the product's market-specific energy label energy consumption data multiplied by the carbon emissions factor for energy in your country or region.

Our In-use Energy Carbon Emissions Estimate is designed to assist customers in making informed purchasing decisions when comparing different Fisher & Paykel products. For example, a heat pump dryer typically has a lower In-use Energy Carbon Emissions Estimate than a vented dryer.



A PEACE OF MIND SALE
24 Hours 7 Days a Week Customer Support
T 1.888.936.7872 W www.fisherpaykel.com