

# 48" Series 11 Professional 4 Burner + 4 Zone Hybrid Self-Cleaning Range, NG

Professional



With both induction and gas cooktops and two convection ovens, you're ready to create a feast - guided by an intuitive touchscreen.

- Guided cooking using your touchscreen makes it simple to cook by food, function or recipe.
- Top burner heat of 23,500 BTU, for seriously fast boiling
- Four induction cooking zones, which can be paired to form two SmartZones
- 6.9 cu ft total oven capacity across two oven cavities

## DIMENSIONS

Height	35 3/4 - 36 3/4 "
Width	47 7/8 "
Depth	29 1/8 "

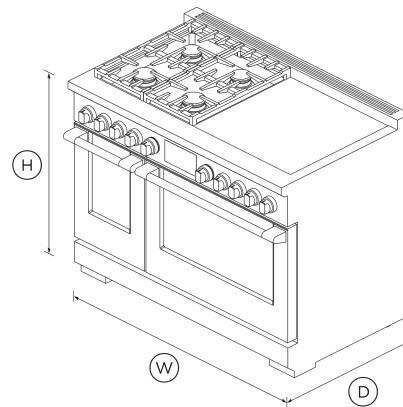

## FEATURES & BENEFITS

### Cook With Confidence

Our touchscreen interface provides an intuitive guided cooking experience that helps deliver perfect results, whether you've been cooking all your life or just starting out. Cook with a favorite method, a hero ingredient, or a go-to cooking function or recipe. The screen tilts for improved ergonomics and optimal visibility while cooking.

### Generous Capacity

Two independently operating cavities provide a large total capacity of 4.8 cu. ft. in the main cavity and 2.1 cu. ft. in the secondary. That's enough room for a 32 lb turkey in one oven, and your sides in the other.

### Cooking Flexibility

No matter what you're cooking, you've got the right heat to get perfect results. Each of the 15 oven functions in the main cavity and 11 in the secondary have been extensively researched and carefully designed to cater to a broad range of dishes and cooking styles. The handy food probe helps you monitor your progress.

### Cooktop Power

On the gas side of the cooktop, Sealed dual flow burners deliver power up to 23,500 BTU, while the induction side delivers up to 3700W. This finely tuned cooktop provides instant and immediate control from the highest heat to the most gentle simmer.

### Design Quality

This range has craftsmanship in every detail, with real stainless steel, high-quality glass, and beautifully weighted, halo illuminated dials. Each cavity features incandescent lights and full extension telescopic racks. From the robust legs to the powerful cooktop, this Range is built to last.

### Easy To Clean

The oven features a self-cleaning function and self-clean proof side racks, which don't need to be removed when using this function. The induction zones only need a quick wipe after use to keep them clean.

## SPECIFICATIONS

### Accessories (included)

- Adjustable feet covers
- Branded coin end cap

**Accessories (sold separately)**

Dial kit Professional, Brass	<b>ADLP3RH484BA</b>
Dial kit Professional, Dark Copper	<b>ADLP3RH484DC</b>

**Burner ratings**

Maximum burner power	<b>23500 BTU</b>
Power back left	<b>18500BTU</b>
Power back right	<b>18500BTU</b>
Power front left	<b>23500BTU</b>
Power front right	<b>18500BTU</b>
Total cooktop power	<b>79000 BTU</b>

**Capacity**

Shelf positions (main oven)	<b>5</b>
Shelf positions (second oven)	<b>5</b>
Total capacity (main oven)	<b>4.8 cu ft</b>
Total capacity second oven	<b>2.1 cu ft</b>
Usable capacity (main oven)	<b>3.8 cu ft</b>

**Cleaning**

Easy clean porcelain basepan	•
Pyrolytic self-clean	•

**Controls**

Dial with illuminated halo	•
Dual control oven dials	•
Electric circuit	<b>4</b>

High resolution display	•
Metal illuminated dials	•
Multi-language interface	•
Precise cooking with food probe	•
Recipe and food based functions	•
Sabbath mode	•
Smart appliance	•
Tilting touch screen interface	•

**Gas Requirements**

Fitting and pipe	<b>½ NPT, min. 5/8" flex line</b>
Supply Pressure (natural gas)	<b>6" to 9" W.C</b>

**Main oven features**

Concealed Element	•
Electronic oven control	•
Full extension telescopic racks	•
Internal light	•
True convection	•

**Main oven functions**

Air fry	•
Bake	•
Classic bake	•
Clean	•
Convection broil	•
Maxi broil	•
Number of oven functions	<b>15</b>

Pizza bake	•
Rapid proof	•
Roast	•
Self cleaning	•
Slow cook	•
True convection	•
Warm	•

**Oven features**

Auto re-ignition system	•
Concealed element	•
Electronic oven control	•
Full extension telescopic sliding shelves	•
True convection	•

**Oven functions**

Air fry	•
Bake	•
Classic bake	•
Clean	•
Convection bake	•
Convection Broil	•
Dehydrate	•
Maxi Broil	•
Number of functions	<b>15</b>
Pastry bake	•
Pizza bake	•
Rapid proof	•
Roast	•

Slow cook	•
True convection	•
Warm	•

SmartZone	2
Vent trim included	•
Zone bridging	•

3/4 Extension racks	2
Electronic oven control	•
Food probe	•
Internal light	•

**Oven performance**

Bake	4600 W
Broil	3600 W
Broil power	4000 W
Main oven - True convection power	2500 W

**Rangetop Performance**

Left front zone rating	2100 (3700) W
Left rear zone rating	2100 (3700) W
Number of cooking zones	4
PowerBoost	•
PowerBoost all zones	up to 3700 W
Right front zone rating	2100 (3700) W
Right rear zone rating	2100 (3700) W

**Secondary oven functions**

Air fry	•
Bake	•
Classic bake	•
Convection bake	•
Convection broil	•
Maxi broil	•
Number of secondary oven functions	11
Pastry bake	•
Pizza bake	•
Rapid proof	•
Roast	•
Warm	•

**Power requirements**

Connection	4-prong grounding type [NEMA 14-50P plug]
Service	50 A
Supply frequency	60 Hz
Supply voltage	208 - 240 V

**Recommended Back Guards Ventilation**

Combustible situation	BGRV3-3048H
Non combustible situation	BGRV2-3048 / BGRV2-1248
Recommended hood	HCB48-12_N (48" Professional Range Hood, Dual Blower)

**Product dimensions**

Depth	29 1/8 "
Height	35 3/4 - 36 3/4 "
Width	47 7/8 "

**Safety**

ADA compliant	•
Pan detection system	•
Safety time out	•
Surface hot indicators	•

SKU 82792

The product dimensions and specifications in this page apply to the specific product and model. Under our policy of continuous improvement, these dimensions and specifications may change at any time. You should therefore check with Fisher & Paykel's Customer Care Centre to ensure this page correctly describes the model currently available. © Fisher & Paykel Appliances Ltd 2020

**Rangetop features**

Gentle heat	•
Heat settings	9
Induction cooking technology	•
Sealed range top	•

**Secondary oven features**

Other product downloads available at [fisherpaykel.com](http://fisherpaykel.com)

- [↓ DWG](#)
- [↓ DWG](#)
- [↓ DWG](#)
- [↓ DXF](#)
- [↓ DXF](#)
- [↓ DXF](#)
- [↓ DXF](#)
- [↓ DXF](#)
- [↓ Archicad](#)
- [↓ DWG](#)
- [↓ Installation Guide \(English\)](#)
- [↓ Installation Guide \(Canadian French\)](#)
- [↓ Planning Guide - 48" Professional Ranges & Backguards \(English\)](#)
- [↓ California Warning Proposition 65 \(English, Spanish, Canadian French, Chinese\)](#)
- [↓ Revit](#)
- [↓ Rhino](#)
- [↓ Right To Repair Declaration \(English, Canadian French\)](#)
- [↓ SketchUp](#)
- [↓ User Guide \(English\)](#)
- [↓ User Guide \(Canadian French\)](#)



**A PEACE OF MIND SALE**  
24 Hours 7 Days a Week Customer Support  
T 1.888.936.7872 W [www.fisherpaykel.com](http://www.fisherpaykel.com)

#### Where applicable:

All appliances use energy, and energy usage typically generates carbon emissions. **Fisher & Paykel Appliances' In-use Energy Carbon Emissions Estimate** indicates carbon emissions from a product's in-use energy. This is calculated either annually or per cycle, using the product's market-specific energy label energy consumption data multiplied by the carbon emissions factor for energy in your country or region.

Our In-use Energy Carbon Emissions Estimate is designed to assist customers in making informed purchasing decisions when comparing different Fisher & Paykel products. For example, a heat pump dryer typically has a lower In-use Energy Carbon Emissions Estimate than a vented dryer.