

Integrated Double DishDrawer™ Dishwasher, Sanitise

Series 9 | Integrated

Panel Ready



Integrating into your kitchen design seamlessly, each drawer fits a half load that you can load and wash independently.

- Knock to pause function is perfect if you miss a dish
- Six wash programs, as well as additional Quick wash, Sanitise and Extra Dry options
- Flexible racking can be folded down to fit bigger dishes
- Customise with your own front panel and handle to match your kitchen cabinetry, or choose our stainless steel panel

DIMENSIONS

Height	820 - 880mm
Width	599mm
Depth	553mm

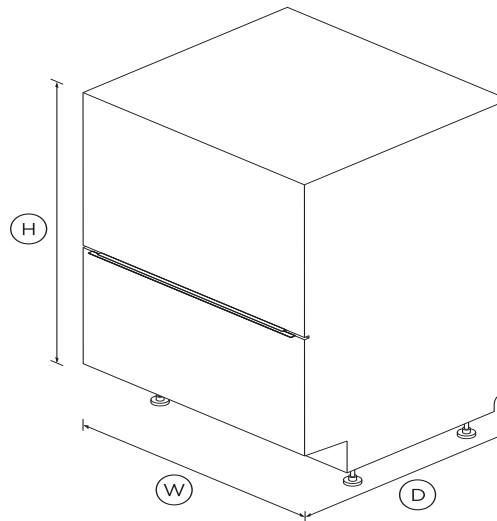

FEATURES & BENEFITS

Seamless integration

Slide your DishDrawer™ Dishwasher into an existing kitchen space or integrate into kitchen cabinetry, for a seamless look whilst delivering superior dish care.

Ease of use

DishDrawer™ Dishwashers are as easy to open and close as kitchen drawers, making loading dishes simple. Flexible racking allows you to make adjustments to fit in a variety of dishes.

INDEPENDENT WASH

With the ability to use both drawers independently and select different wash programs the DishDrawer™ Dishwasher can wash everything from fine glass and crystal to heavily soiled pots and pans.

True Half Load

Each drawer holds a true half load for guilt-free small washes and fast turnaround of your dishes. Both drawers operate independently so different wash cycles can run simultaneously to accommodate a variety of loads.

QUICK, SANITISE AND EXTRA DRY OPTIONS

The Quick wash modifier delivers a faster wash while maintaining performance. The Sanitise option provides extra protection killing 99.9% of bacteria in the final rinse. The Extra Dry setting is perfect for plastic dishes.

Knock to Pause

These DishDrawer™ Dishwashers have a knock to pause function. A knock on the front panel will pause the dishwasher which can be re-started again by using the start/play button.

Quiet performer

Running at a very low decibel rating, these DishDrawer™ Dishwashers do their job without making a fuss. The combination of intelligent technology and simple mechanics means greater reliability and excellent wash performance.

SPECIFICATIONS

Accessories

- Cutlery basket
- Kickstrip
- Knife clip and multipurpose

Accessories (sold separately)

Door panel black stainless steel **ADD60DPB**

Door panel stainless steel **ADDD60DPX**

Capacity and loading

Accommodates round plates **280mm**
 Adjustable height, foldable •
 Fold down tines •
 Pitch adjustable tines •

Consumption

Energy rating **2 ticks**

Controls

Electronic fault/Diagnostic •
 End of cycle beeps •
 Energy saving delay start •
 Internal wash selector •
 Keylock •
 Knock to pause •
 Rinse aid indicator light •

Features

Built-in water softener •
 Fan assisted drying •
 Flood protection •
 Flow through detergent •
 Quiet operation •
 SmartDrive™ technology •

Performance

Noise on standard cycle top **43dBA**

Power requirements

Amperage **10A**
 Supply frequency **50Hz**
 Supply voltage **220 - 240V**

Product dimensions

Depth **553mm**
 Height **820 - 880mm**
 Width **599mm**

Warranty

Parts and labour **2 years**

Wash Program Modifiers

Extra Dry •
 Quick •
 Sanitise •
 Wash modifiers **3**

Wash Programs

Delicate •
 Eco •
 Fast •
 Heavy •
 Medium •
 Rinse •
 Wash programs **6**

Water connection

Water pressure **100kPa - 1000kPa**
 Water supply **3/4" BSP (20mm) Connector**

SKU **82351**

The product dimensions and specifications in this page apply to the specific product and model. Under our policy of continuous improvement, these dimensions and specifications may change at any time. You should therefore check with Fisher & Paykel's Customer Care Centre to ensure this page correctly describes the model currently available. ? Fisher & Paykel Appliances Ltd 2020



A PEACE OF MIND SALE

24 Hours 7 Days a Week Customer Support

T +65 6741 0777 W www.fisherpaykel.com