

30" Series 9 Contemporary Self-Cleaning Double Oven

Contemporary

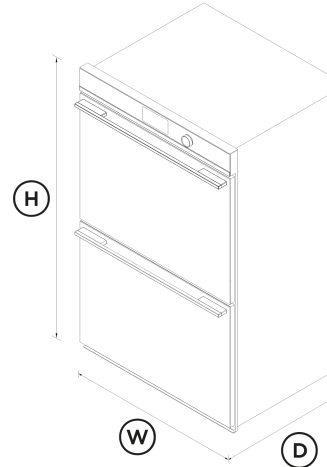

Height	48 1/2 "
Width	29 15/16 "
Depth	23 15/16 "



FEATURES & BENEFITS

Cook With Confidence

Using the large 5" touchscreen interface, you can cook with a favourite method, a hero ingredient, or a go-to cooking function or recipe. Your oven will guide you through the steps, or change the temperature and heat type automatically, depending on your selection.

Generous Capacity

With an incredible 4.1 cu ft total capacity in each oven, you can create several perfectly cooked dishes at once using multiple shelves.

Multi-Function Flexibility

Each function has been tailored, tested and perfected to ensure that no matter what you're cooking, you've got the right heat to match. Purchase our Wireless Temperature Sensor accessory and precisely monitor cooking in real time (accessory sold separately).

Exceptional Performance

AeroTech™ circulates heat evenly for a consistent temperature throughout the cavity, helping you ensure perfect results even when cooking on multiple shelves.

Self-Cleaning

Pyrolytic self-clean breaks down food residue at a very high temperature, leaving a light ash that's easily removed with a damp cloth. The enamel coated side racks don't need to be removed when using this function.

Design Freedom

Designed to fit seamlessly into your kitchen, this built-in oven features premium materials and detailing to support a cohesive, considered kitchen design.

Safe And Sound

The CoolTouch door features triple glazing and a cooling system that ensures it's safe to touch from the outside - protecting both your hands and the surrounding cabinetry.

A highlight of the Fisher & Paykel collection. Ideal for entertaining, with two large ovens to cook multiple dishes at once.

- Touchscreen guided cooking capability offers helpful tips for different food types as well as full recipes
- 4.1 + 4.1 cu ft total capacity across two oven cavities, with 17 oven functions
- Pyrolytic self-cleaning function breaks down food residue for an easy clean
- Non-tip, full extension sliding shelves for safe removal of hot dishes

DIMENSIONS

SPECIFICATIONS

Accessories (included)

Pyrolytic proof shelf runners	•
Wired temperature sensor	1

Cleaning

Acid resistant graphite enamel	•
--------------------------------	---

Descal cycle	•	Pyrolytic self-clean	•
Drying cycle	•	Rapid proof	•
Pyrolytic self-clean	•	Roast	•
Removable oven door	•	Slow cook	•
Removable oven door inner glass	•	True Aero	•
Removable side ladders	•	Vent bake	•
Steam clean (oven)	•	Warm	•

The product dimensions and specifications in this page apply to the specific product and model. Under our policy of continuous improvement, these dimensions and specifications may change at any time. You should therefore check with Fisher & Paykel's Customer Care Centre to ensure this page correctly describes the model currently available. © Fisher & Paykel Appliances Ltd 2020

Other product downloads available at fisherpaykel.com

- [↓](#) DWG
- [↓](#) DXF
- [↓](#) Archicad
- [↓](#) Installation Guide (English, Canadian French)
- [↓](#) Planning Guide - Contemporary 30" Built-in Ovens and Companions (English)
- [↓](#) Planning Guide - Contemporary 30" Built-in Ovens and Companions (Canadian French)
- [↓](#) Planning Guide - Contemporary 30" Built-in Ovens and Companions (Spanish)
- [↓](#) California Warning Proposition 65 (English, Spanish, Canadian French, Chinese)
- [↓](#) Revit
- [↓](#) Rhino
- [↓](#) Right To Repair Declaration (English, Canadian French)
- [↓](#) SketchUp
- [↓](#) User Guide (English)
- [↓](#) User Guide (Canadian French)
- [↓](#) User Guide (Spanish)

Controls

Dial with illuminated halo	•
Internal Light	•
Intuitive touchscreen display	•
Multi-language display	•
Sabbath mode with Star K certification	•
Smart appliance	•
Soft close doors	•

UK English

Performance

ActiveVent™ system	•
AeroTech™ technology	•

Power Requirements

Amperage	39 A
Supply voltage	208 - 240 V

Functions

Aero Broil	•
Aero™ Bake	•
Air fry	•
Bake	•
Broil	•
Classic bake	•
Dehydrate	•
Maxi Broil	•
Number of functions	16
Pastry Bake	•
Pizza bake	•

Product Dimensions

Depth	23 15/16 "
Height	48 1/2 "
Width	29 15/16 "

SKU	82772
-----	--------------

Where applicable:

All appliances use energy, and energy usage typically generates carbon emissions. **Fisher & Paykel Appliances' In-use Energy Carbon Emissions Estimate** indicates carbon emissions from a product's in-use energy. This is calculated either annually or per cycle, using the product's market-specific energy label energy consumption data multiplied by the carbon emissions factor for energy in your country or region.

Our In-use Energy Carbon Emissions Estimate is designed to assist customers in making informed purchasing decisions when comparing different Fisher & Paykel products. For example, a heat pump dryer typically has a lower In-use Energy Carbon Emissions Estimate than a vented dryer.



A PEACE OF MIND SALE
24 Hours 7 Days a Week Customer Support
T 1.888.936.7872 W www.fisherpaykel.com