

Oven, 60cm, 7 Function, Self-cleaning

Series 5 | Contemporary



With generous capacity and beautiful contemporary styling, this built-in oven will complement your kitchen design perfectly.

- 85L total capacity
- Seven oven functions including Pastry Bake
- Pyrolytic self-cleaning function breaks down food residue for an easy clean

DIMENSIONS

Height	598mm
Width	597mm
Depth	565mm

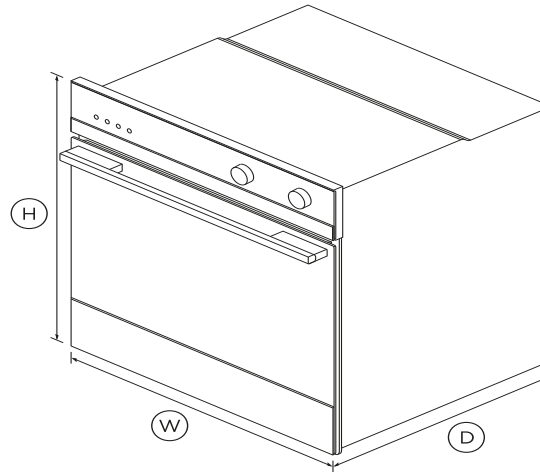

FEATURES & BENEFITS

Cooking flexibility

This built-in oven has seven functions with pre-set temperatures, including Bake, Fan Bake and Fan Forced allowing you to use a variety of cooking styles.

Self cleaning

The self-clean function breaks down food residue at a very high temperature, leaving a light ash that's easily removed with a damp cloth. For best results, wipe down the inside of your oven door before you use the self-clean function.

Sized to suit

Designed for multi-shelf cooking, this is one of the largest built-in ovens on the market with 85L of capacity. The higher internal cavity allows you to fit a large casserole dish, the family roast and a pie for dessert.

Safe and sound

The CoolTouch door with triple glazing and cooling system is safe to touch from the outside, protecting your hands and the surrounding cabinetry. Getting large dishes in and out of the oven is a breeze with non-tip shelves.

Even cooking

Our built-in ovens feature AeroTech™ – a technology that circulates heat evenly, ideal for multi-shelf cooking.

Complementary design

With their premium handle styling and stainless steel finish, our built-in ovens are designed to match the rest of Fisher & Paykel's kitchen appliance family.

SPECIFICATIONS

Accessories

Telescopic sliding runners	1 set
----------------------------	-------

Accessories (sold separately)

Handle kit Contemporary	Part number 81645
-------------------------	-------------------

Capacity

Shelf positions	6
Total capacity	85L
Usable capacity	72L

Cleaning

- Acid resistant graphite enamel •
- Pyrolytic self-clean •
- Removable oven door inner •
- Removable shelf runners •

Consumption

Energy rating	A
Energy usage	0.80kWh/cycle
In-use energy carbon	0.2kgCO2e/cycle

Controls

- Audio feedback •
- Automatic cooking/minute •
- Automatic pre-set •
- Celsius/Fahrenheit •
- Dial with illuminated halo •
- Electronic capacitive touch •
- Electronic clock •
- Electronic oven control •

Functions

- Bake •
- Fan bake •
- Fan forced •
- Fan grill •
- Grill •
- Number of functions **7**
- Pastry Bake •
- Pyrolytic self-clean •

Performance

- AeroTech™ technology •
- Automatic rapid pre-heat •
- Grill power **3000W**

Power requirements

Amperage	15A
----------	------------

Product dimensions

Depth	565mm
Height	598mm
Width	597mm

Safety

- Balanced oven door •
- Catalytic venting system •
- Control panel key lock •
- Non-tip shelves •

Warranty

Parts and labour	5 years
------------------	----------------

SKU	81532
-----	--------------

The product dimensions and specifications in this page apply to the specific product and model. Under our policy of continuous improvement, these dimensions and specifications may change at any time. You should therefore check with Fisher & Paykel's Customer Care Centre to ensure this page correctly describes the model currently available. ? Fisher & Paykel Appliances Ltd 2020



A PEACE OF MIND SALE

24 Hours 7 Days a Week Customer Support

T 08000 886 605 Wwww.fisherpaykel.com