

Wall Rangehood, 90cm, Box Chimney

Series 7 | Contemporary

Stainless Steel and Glass



Engineered for optimum extraction of fumes, smoke and vapour. The powerful fan removes cooking odours and grease from the kitchen quietly and efficiently.

- Variable fan speed, for more flexibility in selecting the perfect extraction rate for your cooking
- Exceptionally powerful maximum air movement of 1020m³/hr
- 4 energy-efficient LED lights to illuminate your cooking surface
- Grease management system

DIMENSIONS

Height	625 - 930mm
Width	895mm
Depth	535mm

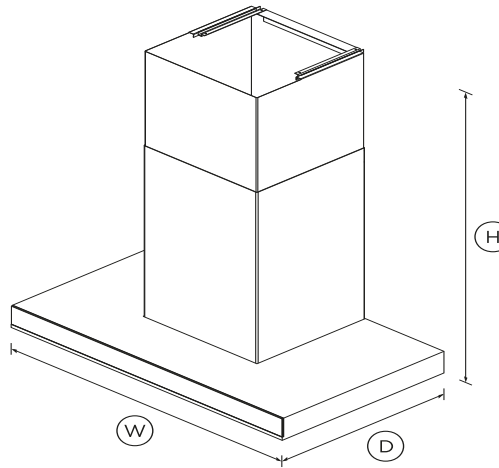

SPECIFICATIONS

Accessories (sold separately)

Chimney extension	792492
Ducting solution	•

Fan ratings

Maximum air movement	1080m ³ /hr
Maximum sound rating	68dBA

Installation and cleaning

Ducted	Top extraction
Two piece height adjustable	•

Performance

Extraction type	Surface
Fan speeds	Variable
Filter type	Stainless Steel Baffle, Oil filter

Power requirements

Lighting power	2W
Motor power	150W
Total Power	158W

Product dimensions

Depth	535mm
Height	625 - 930mm
Width	895mm

Product information

Control type	Soft-touch
--------------	------------

Ventilation features

Light type	LED
------------	-----

SKU	81336
-----	-------

The product dimensions and specifications in this page apply to the specific product and model. Under our policy of continuous improvement, these dimensions and specifications may change at any time. You should therefore check with Fisher &

Paykel's Customer Care Centre to ensure this page correctly describes the model currently available. ? Fisher & Paykel Appliances Ltd 2020

Other product downloads available at fisherpaykel.com



Installation & User Guide EN /  ZH



Service & Warranty



A PEACE OF MIND SALE

24 Hours 7 Days a Week Customer Support

T 400 640 8777 **W**www.fisherpaykel.com