

Oven, 60cm, 16 Function, Self-cleaning

Series 9 | Contemporary

Stainless Steel



A highlight of the Fisher & Paykel collection, this Series 9 oven with touchscreen ensures that every dish is cooked to perfection.

- Touchscreen guided cooking capability offers helpful tips for different food types as well as full recipes
- 85L total capacity with 16 oven functions including Roast and Pastry Bake
- Moisture level control with ActiveVent™ technology
- Pyrolytic self-cleaning function breaks down food residue for an easy clean

DIMENSIONS

Height	598mm
Width	596mm
Depth	565mm

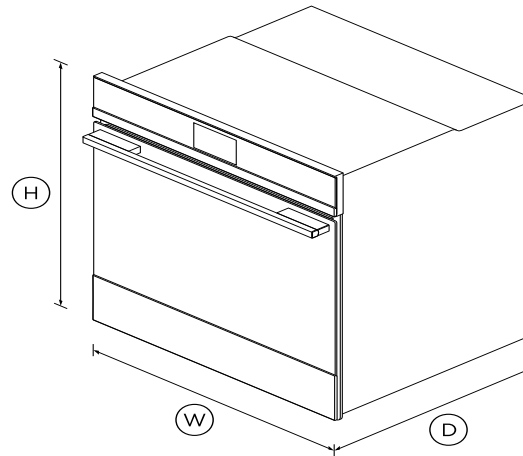

FEATURES & BENEFITS

Cook with confidence

Our touchscreen interface provides an intuitive guided cooking experience that helps deliver perfect results, whether you've been cooking all your life or just starting out. Cook with a favourite method, a hero ingredient, or a go-to cooking function or recipe.

Generous capacity

With its market-leading 3 cu ft total capacity, you can create several perfectly cooked dishes at once using multiple shelves.

Multi-function flexibility

The cooking functions have each been tailored, tested, tweaked and perfected to ensure that no matter what you're cooking, you've got the right heat to match. Purchase our Wireless Temperature Sensor accessory and precisely monitor cooking in real time (accessory sold separately).

Exceptional performance

Our unique cooking technologies were developed to deliver perfect results. ActiveVent ensures optimised moisture levels, while AeroTech™ circulates heat evenly for a consistent temperature.

Self-cleaning

Our self-clean technology breaks down food residue at a very high temperature, leaving light ash easily removed with a damp cloth. The enamel-coated side racks don't need to be removed when using this function.

Design freedom

Available in an elegant black or a stylish black with stainless steel, this oven is designed to fit seamlessly into your kitchen. Premium materials and detailing to support a cohesive, considered kitchen design.

SPECIFICATIONS

Accessories

Full extension sliding shelves	2 sets
Grill rack	1 set
Roasting dish	1
Smokeless grill tray	1
Step down wire shelf	1
Wired temperature sensor	1

Accessories (sold separately)

Optional Accessory round	Part 81645
--------------------------	------------

Capacity

Shelf positions	6
Total capacity	85L
Usable capacity	72L

Cleaning

Acid resistant graphite enamel	•
Pyrolytic self-clean	•
Removable oven door	•
Removable oven door inner	•
Removable shelf runners	•

Controls

Adjustable audio and display	•
Automatic cooking/minute	•
Automatic pre-set	•
Celsius/Fahrenheit	•
Certified Sabbath mode	•
Electronic clock	•
Electronic oven control	•
Food probe	•
Guided cooking by food type	•
Intuitive touchscreen display	•
Multi-language display	UK English, US English,
Soft close doors	•

Functions

Bake	•
------	---

Classic bake	•
Fan bake	•
Fan forced	•
Fan grill	•
Grill	•
Number of functions	16
Pastry Bake	•
Pizza bake	•
Pyrolytic self-clean	•
Rapid proof	•
Roast	•
Slow cook	•
Vent bake	•
Warm	•

Performance

ActiveVent™ system	•
AeroTech™ technology	•
Automatic rapid pre-heat	•
Grill power	3000W
Whisper quiet cooking	•

Power requirements

Amperage	15A
Supply frequency	50Hz
Supply voltage	220 - 240V

Product dimensions

Depth	565mm
Height	598mm

Width	596mm
-------	--------------

Safety

Balanced oven door	•
Catalytic venting system	•
Control panel key lock	•
CoolTouch door	•
Non-tip shelves	•

Warranty

Parts and labour	2 years
------------------	----------------

SKU	82275
-----	--------------

The product dimensions and specifications in this page apply to the specific product and model. Under our policy of continuous improvement, these dimensions and specifications may change at any time. You should therefore check with Fisher & Paykel's Customer Care Centre to ensure this page correctly describes the model currently available. ? Fisher & Paykel Appliances Ltd 2020



A PEACE OF MIND SALE

24 Hours 7 Days a Week Customer Support

T +65 6741 0777 W www.fisherpaykel.com