

Integrated Refrigerator Freezer, 90.6cm, Ice

Series 7 | Integrated

Panel Ready | Right Hinge



Choose a roomy refrigerator with ice maker. Fits flush with your custom cabinetry or with our stainless steel panels.*

- Customise with your own kitchen cabinetry or purchase our stainless steel door panel accessory
- Internal ice maker with boost feature for busy times
- Spacious bottom freezer with full extension drawer gives easy access to frozen goods

DIMENSIONS

Height	2030mm
Width	910mm
Depth	602mm

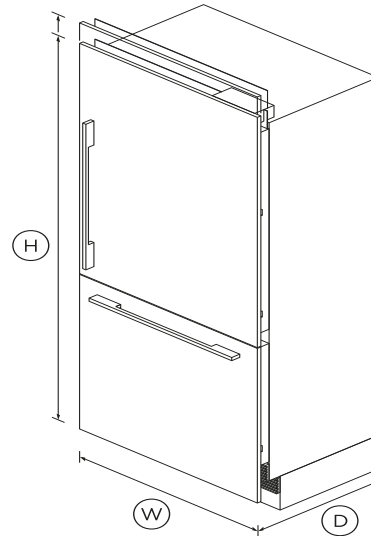

FEATURES & BENEFITS

NO MORE GAPS

Our integrated products are designed to seamlessly integrate with your kitchen. This fridge will fit flush with your cabinetry for a seamless finish.

Simple storage

This fridge is designed to make it simple for you to store, access and remove food. Storage bins give you full access inside when they're pulled open and can be easily removed to clean. Our flexible shelving also gives you more storage options.

Ice Maker

Fresh ice is always available for you in a dedicated freezer bin. Simply turn it off to free up freezer space or during busy times, you can boost ice production by up to 30%.

CLEVER ENERGY

Your fridge adapts to daily use by cooling and defrosting only when needed. This ActiveSmart™ technology means better energy efficiency without compromising on food care.

Easy cleaning

Spill-safe secure glass shelves easily capture any drips or leaks and prevent them from falling on items below.

DESIGN QUALITY

Our fridges are designed and built using quality materials. We use real stainless steel on our fridges and solid glass for shelving.

Activesmart™ Foodcare

ActiveSmart™ Foodcare learns how you live. It's technology which understands how you use your refrigerator and adjusts temperature, airflow and humidity inside to help keep food fresher for longer.

SPECIFICATIONS

Accessories (sold separately)

Door panel stainless steel	Left hinge = RD9120WL
Handle kit Contemporary	AHS-ASBI-B
Handle kit Contemporary	AHD5RD9120W
Handle kit Contemporary	AHD5RD9120WB
Handle kit Contemporary	RS91W
Joiner kit	RS91W
Water filter replacement	847200 - FWC3

Capacity

Volume	477L
--------	------

Volume freezer	145L
Volume refrigerator	332L

Consumption

Energy rating	3.5 star
Energy usage	409kWh/year
In-use energy carbon	55.4kgCO2e/year

Features

Adjustable door shelves	6
Adjustable glass cantilevered	•
Adjustable glass shelves	3
Covered door shelves	2
Door alarm	•
Fruit and vegetable bins	2
Full extension runners	•
LED lighting	•
SmartTouch control panel	•
Spill proof removable bins	•
Stackable bottle holders	4

Freezer Features

Automatic ice maker	•
Bottle chill	•
Door alarm	•
Fast freeze	•
Ice Boost	•
LED lighting	•
Large plastic bins	•

Slide Out Pastry Tray	•
-----------------------	---

Performance

ActiveSmart™ Foodcare	•
Adaptive defrost	•
Frost free freezer	•
Humidity control system	•
Inverter controlled compressor	•
Sabbath mode	•

Power requirements

Supply frequency	50Hz
Supply voltage	220 - 230V

Product dimensions

Depth	602mm
Height	2030mm
Width	910mm

Warranty

Parts and labour	2 years
------------------	---------

SKU	26626
-----	-------

The product dimensions and specifications in this page apply to the specific product and model. Under our policy of continuous improvement, these dimensions and specifications may change at any time. You should therefore check with Fisher & Paykel's Customer Care Centre to ensure this page correctly describes the model currently available. Fisher & Paykel Appliances Ltd 2020

Where applicable:

All appliances use energy, and energy usage typically generates carbon emissions. **Fisher & Paykel Appliances' In-use Energy Carbon Emissions Estimate** indicates carbon emissions from a product's in-use energy. This is calculated either annually or per cycle, using the product's market-specific energy label energy consumption data multiplied by the carbon emissions factor for energy in your country or region.

Our In-use Energy Carbon Emissions Estimate is designed to assist customers in making informed purchasing decisions when comparing different Fisher & Paykel products. For example, a heat pump dryer typically has a lower In-use Energy Carbon Emissions Estimate than a vented dryer.

Other product downloads available at fisherpaykel.com



Service & Warranty



Energy Label Integrated Refrigerator Freezer



User Guide Integrated Refrigerator Freezer



Dual Installation Guide EN



A PEACE OF MIND SALE

24 Hours 7 Days a Week Customer Support

T 0800 372 273 [Wwww.fisherpaykel.com](http://www.fisherpaykel.com)