

30" Series 9 Professional 4 Burner Dual Fuel Self-Cleaning Range, Natural Gas

Professional



Get the best of gas and convection technology in this striking range with intuitive touchscreen and specialized cooking functions.

- Guided cooking using your touchscreen makes it simple to cook by food, function or recipe.
- Top burner heat of 22,500 BTU, for seriously fast boiling
- 4 cu ft total oven capacity
- Beautiful LED halo-illuminated dials provide information at a glance

DIMENSIONS

Height	35 3/4 - 36 3/4 "
Width	29 7/8 "
Depth	29 1/8 "

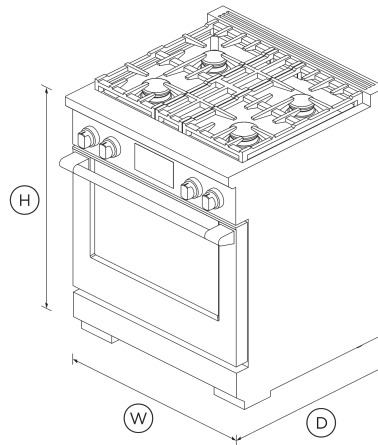

FEATURES & BENEFITS

Cook With Confidence

Our touchscreen interface provides an intuitive guided cooking experience that helps deliver perfect results, whether you've been cooking all your life or just starting out. Cook with a favorite method, a hero ingredient, or a go-to cooking function or recipe. The screen tilts for improved ergonomics and optimal visibility while cooking.

Generous Capacity

Featuring a generous total capacity of 4 cu ft, with enough room to fit a 26 lb turkey, or to cook several dishes at once.

Cooking Flexibility

No matter what you're cooking, you've got the right heat to get perfect results. Each of the 15 oven functions have been extensively researched and carefully designed to cater to a broad range of dishes and cooking styles. The handy food probe helps you monitor your progress.

Cooktop Power

Sealed dual flow burners deliver cooktop power up to 22,500 BTU for seriously fast boiling, and precise 140°F full surface, low temperature cooking with the gentlest of flames

Design Quality

This range has craftsmanship in every detail, with real stainless steel, cast-iron grates, and beautifully weighted, halo illuminated dials. Each cavity features incandescent lights and full extension telescopic racks. From the robust legs to the powerful cooktop, this Range is built to last.

Easy To Clean

The oven features a self-cleaning function and self-clean proof side racks, which don't need to be removed when using this function.

SPECIFICATIONS

Accessories (included)

- Adjustable feet covers
- Branded coin end cap

Accessories (sold separately)

- Square handle option **AH-R30**

Burner ratings

Maximum burner power	22500 BTU
Power back left	18500BTU
Power back right	18500BTU
Power front left	22500BTU
Power front right	18500BTU
Total cooktop power	78000 BTU

Capacity

Shelf positions	5
-----------------	----------

Cleaning

Easy clean porcelain basepan	•
Pyrolytic self-clean	•

Consumption

Energy usage	490kWh/year
In-use energy carbon emissions estimate	56.5kgCO2e/year

Controls

Dial with illuminated halo	•
Electric circuit	4
High resolution display	•
Metal illuminated dials	•
Multi-language interface	•
Precise cooking with food probe	•
Recipe and food based functions	•
Sabbath mode	•

Smart appliance	•
Tilting touch screen interface	•

Gas Requirements

Fitting and pipe	½ NPT, min. ⅝" flex line
Supply Pressure (natural gas)	6" to 9" W.C

Main oven functions

Warm	•
------	---

Oven features

Auto re-ignition system	•
Broil pan	•
Concealed element	•
Electronic oven control	•
Food probe	•
Full extension telescopic sliding shelves	•
Self-clean proof side racks	•
Titanium coated, illuminated metal dials	•

Oven functions

Air fry	•
Bake	•
Classic bake	•
Clean	•
Convection bake	•
Convection Broil	•

Dehydrate	•
Maxi Broil	•
Number of functions	15
Pastry bake	•
Pizza bake	•
Rapid proof	•
Roast	•
Slow cook	•
True convection	•
Warm	•

Oven performance

Bake power	3500
Main oven - True convection power	2500 W

Power requirements

Connection	4-prong grounding type [NEMA 14-50 plug]
Service	30 A
Supply frequency	60 Hz
Supply voltage	240 V

Product details

Self Cleaning Sf	Yes
------------------	------------

Product dimensions

Depth	29 1/8 "
-------	-----------------

Depth (excluding handles)	2918 mm
Height	35 3/4 - 36 3/4 "
Width	29 7/8 "

The product dimensions and specifications in this page apply to the specific product and model. Under our policy of continuous improvement, these dimensions and specifications may change at any time. You should therefore check with Fisher & Paykel's Customer Care Centre to ensure this page correctly describes the model currently available. © Fisher & Paykel Appliances Ltd 2020

All appliances use energy, and energy usage typically generates carbon emissions. **Fisher & Paykel Appliances' In-use Energy Carbon Emissions Estimate** indicates carbon emissions from a product's in-use energy. This is calculated either annually or per cycle, using the product's market-specific energy label energy consumption data multiplied by the carbon emissions factor for energy in your country or region.

Rangetop features

- Sealed range top •
- Vent trim included •

Other product downloads available at fisherpaykel.com

- ↓ DWG
- ↓ DWG
- ↓ DWG
- ↓ DXF
- ↓ DXF
- ↓ DXF
- ↓ Archicad
- ↓ Energy Label
- ↓ Installation Guide (English)
- ↓ Installation Guide (Canadian French)
- ↓ Planning Guide - 30" Professional Ranges & Backguards (English)
- ↓ Revit
- ↓ Rhino
- ↓ Right To Repair Declaration (English, Canadian French)
- ↓ SketchUp
- ↓ User Guide (English)
- ↓ User Guide (Canadian French)

Where applicable:

Recommended Back Guards Ventilation

Combustible situation	BGRV3-3030H
Non combustible situation	BGRV2-3030 / BGRV2-1230
Recommended hood	HCB30-6_N (Professional Range Hood)

Our In-use Energy Carbon Emissions Estimate is designed to assist customers in making informed purchasing decisions when comparing different Fisher & Paykel products. For example, a heat pump dryer typically has a lower In-use Energy Carbon Emissions Estimate than a vented dryer.



A PEACE OF MIND SALE
24 Hours 7 Days a Week Customer Support
 T 1.888.936.7872 Wwww.fisherpaykel.com

Safety

- ADA compliant •
- Full extension telescopic sliding shelves •

Secondary oven features

- Food probe •

SKU 82943