

30" Series 9 Professional 4 Burner Dual Fuel Range, Natural Gas

Height	35 3/4 - 36 3/4 "
Width	29 7/8 "
Depth	29 1/8 "

The Dual Fuel Range broiler provides an even heat that covers a very large surface area — perfect for browning a fully loaded oven tray.

Easy To Clean

The Dual Fuel Range oven has a self-cleaning function and removable side racks. The cooktop has sealed burners and an encapsulated cooking surface with a commercial-style stainless steel finish.

Instant Visibility

Control dials have halo-illumination glowing white - heating up; orange - temperature reached; red - self-cleaning mode. The oven is illuminated by two powerful incandescent lights.

Cooking Flexibility

The cooktop is designed for easy access to any burner, with grates you can smoothly slide pots across, while the oven cavity is large enough to allow you to cook multiple dishes at once.

SPECIFICATIONS

Accessories (sold separately)

Square handle option	AH-R30
Wok grate included	Yes

Burner ratings

Maximum burner power	22500 BTU
Power back left	18500BTU
Power back right	18500BTU
Power front left	22500BTU
Power front right	18500BTU
Total cooktop power	78000 BTU

Professional



Make a statement in your kitchen with this Professional style range for powerful gas and convection cooking.

- Top burner heat of 22,500 BTU, for seriously fast boiling
- Convection oven with 4 cu ft total capacity
- Non-tip full-extension shelves for safe removal of hot dishes

DIMENSIONS

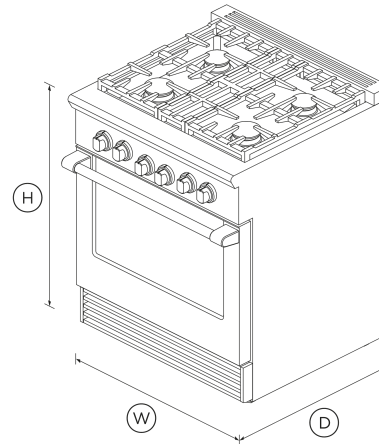

FEATURES & BENEFITS

Cooktop Power

Sealed Dual Flow Burners™ deliver cooktop power up to 22,500 BTU (NG models) for seriously fast boiling right down to a precise 140°F full surface simmer with the gentlest of flames.

Total Control

Precise control across high and low settings is delivered through the halo-illuminated cooktop dials. The ovens have true convection and electronic oven control for precise and consistent temperatures.

Consistent Broiling

Capacity	
Shelf positions (main oven)	5
Total capacity (main oven)	4 L

Cleaning	
Pyrolytic self-clean	•

Controls	
Electric circuit	4
Metal illuminated dials	•

Gas Requirements	
Fitting and pipe	½ NPT, min. 5/8" flex line
Supply Pressure (natural gas)	6" to 9" W.C

Oven features	
Auto re-ignition system	•
Broil pan	•
Concealed element	•
Electronic oven control	•
True convection	•

Oven functions	
Bake	•
Broil	•

Clean	•
Convection bake	•
Convection Broil	•
Number of functions	6
True convection	•

Oven performance	
Bake power	3500
Main oven - True convection power	2500 W

Power requirements	
Rated current	30 A
Supply frequency	60 Hz

Product dimensions	
Depth	29 1/8 "
Depth (excluding handles)	2918 mm
Height	35 3/4 - 36 3/4 "
Width	29 7/8 "

Rangetop features	
Sealed range top	•
Vent trim included	•

Safety	
Full extension telescopic sliding shelves	•

SKU 71372

The product dimensions and specifications in this page apply to the specific product and model. Under our policy of continuous improvement, these dimensions and specifications may change at any time. You should therefore check with Fisher & Paykel's Customer Care Centre to ensure this page correctly describes the model currently available. © Fisher & Paykel Appliances Ltd 2020

Other product downloads available at fisherpaykel.com

- [↓](#) DWG
- [↓](#) DWG
- [↓](#) DXF
- [↓](#) DXF
- [↓](#) Archicad
- [↓](#) Data Sheet (English)
- [↓](#) Revit
- [↓](#) SketchUp
- [↓](#) DWG
- [↓](#) DXF
- [↓](#) Archicad
- [↓](#) Data Sheet (English)
- [↓](#) Installation Guide (English, Canadian French)
- [↓](#) Planning Guide (English)
- [↓](#) Revit
- [↓](#) Right To Repair Declaration (English, Canadian French)
- [↓](#) SketchUp
- [↓](#) User Guide (English)
- [↓](#) User Guide (Canadian French)

Where applicable:

All appliances use energy, and energy usage typically generates carbon emissions. **Fisher & Paykel Appliances' In-use Energy Carbon Emissions Estimate** indicates carbon emissions from a product's in-use energy. This is calculated either annually or per cycle, using the product's market-specific energy label energy consumption data multiplied by the carbon emissions factor for energy in your country or region.

Our In-use Energy Carbon Emissions Estimate is designed to assist customers in making informed purchasing decisions when comparing different Fisher & Paykel products. For example, a heat pump dryer typically has a lower In-use Energy Carbon Emissions Estimate than a vented dryer.



A PEACE OF MIND SALE
24 Hours 7 Days a Week Customer Support
T 1.888.936.7872 W www.fisherpaykel.com