

Heat Pump Dryer, 9kg

Series 9 | Heat Pump

White



Better energy efficiency and fabric care with heat pump condensing technology, which dries your clothes at a lower temperature.

- 18 dry cycles, including 5 extra care cycles
- 8 Star Energy Rating
- Auto-sensing detects moisture levels to prevent under or over drying
- No need for external venting, allowing your dryer to be placed anywhere in your home

DIMENSIONS

Height	850mm
Width	600mm
Depth	670mm

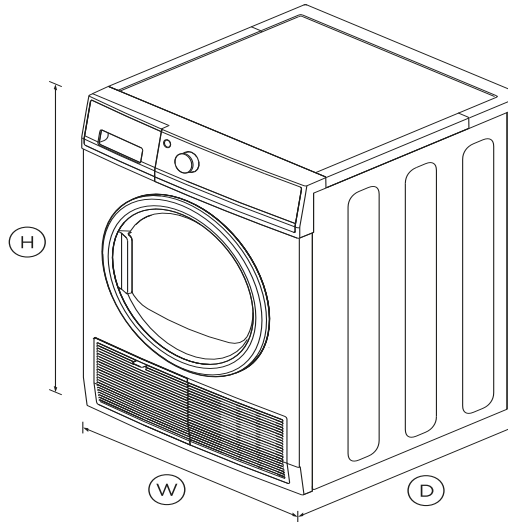

FEATURES & BENEFITS

18 fabric care cycles

Intuitive controls with clever drying hints help you get the best results. Easy to use, the LCD display provides a simple interface to select from 18 dry cycles; including Ultra-delicate for lace; Outdoor for high performance fabrics; a Warm-up cycle for towels; Jeans for everyday essentials; and Soft Toys for those special items.

HEAT PUMP TECHNOLOGY

Heat pump technology dries at lower temperatures for gentle fabric care and because moisture is condensed, no venting is required. This is an ideal dryer for laundries where venting is

difficult as it can be placed almost anywhere in the home.

Auto-sensing technology

Auto-sensing technology measures moisture inside the drum, shutting off at the perfect time to avoid over-drying your clothes, helping them last longer and reducing energy wastage.

8 star energy rating

This dryer uses heat pump technology to gently and effectively dry clothes at low temperatures, and achieves an outstanding 8 star energy rating

Too precious to tumble?

The drying rack is designed for items that can't be tumble dried. It fits easily into the dryer and delivers the perfect result for those precious delicates, shoes and toys.

DESIGNED TO MATCH

The Heat Pump Condensing Dryer is designed to match beautifully with any Fisher & Paykel front loader washing machine, creating the perfect pair to deliver complete fabric care.

SPECIFICATIONS

Consumption

Energy rating **5 ticks**

Dry Cycles

Bulky	•
Cool air	•
Delicate	•
Easy Iron	•
Everyday	•
Heavy	•
Jeans	•
Number of cycles	18

- Outdoor •
- Rack dry •
- Sheets •
- Soft toys •
- Sports •
- Time dry •
- Towels •
- Ultra delicate •
- Warm up •
- Wool •

- Time to go •
- Wrinkle free option •

Performance

- Auto sensing •
- Dryness settings **5** •
- Heat pump technology •
- Reverse tumbling •
- Time dry **30,40,50... 150 mins** •

Product dimensions

- Depth **670mm**
- Height **850mm**
- Width **600mm**

Warranty

- Parts and labour **2 years**

SKU **93273**

The product dimensions and specifications in this page apply to the specific product and model. Under our policy of continuous improvement, these dimensions and specifications may change at any time. You should therefore check with Fisher & Paykel's Customer Care Centre to ensure this page correctly describes the model currently available. ? Fisher & Paykel Appliances Ltd 2020

Other product downloads available at fisherpaykel.com

 [Service & Warranty](#)



A PEACE OF MIND SALE

24 Hours 7 Days a Week Customer Support

T +65 6741 0777 W www.fisherpaykel.com