

90cm Series 7 Integrated French Door Refrigerator Freezer, Ice & Water

Integrated



This large capacity refrigerator with bottom freezer seamlessly integrates into your kitchen, fitting flush into your cabinetry.

- ActiveSmart™ technology helps keep food fresher for longer by constantly maintaining the ideal temperature
- SmartTouch control panel ensures ease of use
- Spacious bottom freezer featuring a full-extension drawer and an ice maker with boost function
- Stainless steel door panels and handles are available for separate purchase

DIMENSIONS

Height	1798 mm
Width	896 mm
Depth	606 mm

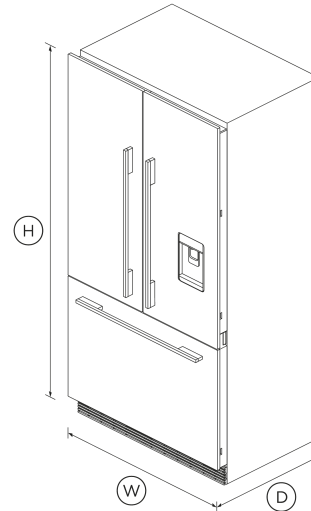

FEATURES & BENEFITS

Perfect Fit

These models fit flush and have minimal gaps, with no visible hinges. Purchase our stainless steel door panel and handles separately for a sleek, modern finish that complements your kitchen's style.

ActiveSmart™ Foodcare

ActiveSmart™ Foodcare learns how you live. By understanding how you use your refrigerator and adjusting temperature, airflow and humidity inside, it helps keep food fresher for longer.

Flexible Storage

Designed to make it simple for you to store, sort and access food. Storage bins give you full access inside when they're pulled open and can be easily removed to clean. Our cantilevered shelving also gives you more storage options.

Water dispenser

The slimline dispenser makes it easy to fill almost any sized jug or vessel with cool filtered water without taking up any storage space in your fridge.

Ice maker

Fresh ice is always available for you in a dedicated freezer bin. Simply turn it off to free up freezer space or during busy times, you can boost ice production by up to 30%.

Beautiful Lighting

LED lighting illuminates the interior with a crisp, clean glow for enhanced visibility. Our energy saving LEDs use less power than comparable halogen lights.

Easy Cleaning

No more permanent dirty marks with our EZKleen feature for stainless steel refrigerators. Anti-fingerprint coating means you simply wipe clean any marks. Spill-safe secure glass shelves easily capture any drips or leaks.

SPECIFICATIONS

Accessories (sold separately)

Door panel set stainless steel	RD90AU
Handle kit Classic	AHCLR90A
Handle kit Contemporary round, aluminium	AHS-ASBI-A

Handle kit Contemporary square fine, aluminium	AHD5RD90A
Handle kit Contemporary square fine, black	AHD5RD90AB
Handle kit Professional round flush	AHP3RD90A
Water filter replacement	847200 - FWC3

Capacity

Volume freezer	145 L
Volume refrigerator	331 L

Connected Features

Alerts and notifications	•
Cyber security updates until	19 / 12 / 2029
Education and onboarding	•
Remote operation	•
Software updates	•

Consumption

Energy rating	3.5 star
Energy usage	413kWh/year (IEC 62552-2015), 422kWh/year (AS/NZS 4474.2:2009)
In-use energy carbon emissions estimate	252.0kgCO2e/year (IEC 62552-2015), 257.5kgCO2e/year (AS/NZS 4474.2:2009)

Features

Adjustable door shelves	6
Adjustable glass cantilevered shelves	•
Adjustable glass shelves	3
Covered door shelves	2
Deli storage bins	1
Door alarm	•
Fruit and vegetable bins	2
LED lighting	•
Smart appliance	•
SmartTouch control panel	•
Soft close doors	•
Stackable bottle holders	4
Ultra slim water dispenser	•

Freezer Features

Automatic ice maker	•
Bottle chill	•
Door alarm	•
Fast freeze	•
Ice Boost	•
Large plastic bins	•
LED Lighting	•
Slide Out Pastry Tray	•

Performance

ActiveSmart™ Foodcare	•
Adaptive defrost	•
Frost free freezer	•
Humidity control system	•

Inverter controlled compressor	•
Sabbath mode	•

Power requirements

Rated current	10 A
Supply frequency	50 Hz
Supply voltage	230 - 240 V

Product dimensions

Depth	606 mm
Height	1798 mm
Width	896 mm

Variable Temp Compartment

Bottle chill mode	•
-------------------	---

SKU	26843
-----	--------------

The product dimensions and specifications in this page apply to the specific product and model. Under our policy of continuous improvement, these dimensions and specifications may change at any time. You should therefore check with Fisher & Paykel's Customer Care Centre to ensure this page correctly describes the model currently available. © Fisher & Paykel Appliances Ltd 2020

Other product downloads available at fisherpaykel.com

- [↓](#) DWG
- [↓](#) DWG
- [↓](#) DXF
- [↓](#) DXF
- [↓](#) Archicad
- [↓](#) Energy Label
- [↓](#) Installation Guide (English)
- [↓](#) Planning Guide (English)
- [↓](#) Revit
- [↓](#) Rhino
- [↓](#) SketchUp
- [↓](#) User Guide (English)

Where applicable:

All appliances use energy, and energy usage typically generates carbon emissions. **Fisher & Paykel Appliances' In-use Energy Carbon Emissions Estimate** indicates carbon emissions from a product's in-use energy. This is calculated either annually or per cycle, using the product's market-specific energy label energy consumption data multiplied by the carbon emissions factor for energy in your country or region.

Our In-use Energy Carbon Emissions Estimate is designed to assist customers in making informed purchasing decisions when comparing different Fisher & Paykel products. For example, a heat pump dryer typically has a lower In-use Energy Carbon Emissions Estimate than a vented dryer.



A PEACE OF MIND SALE
24 Hours 7 Days a Week Customer Support
T 1300 650 590 W www.fisherpaykel.com