

Freestanding Refrigerator Freezer, 63.5cm, 380L

Series 5 | Contemporary

Stainless Steel | Right Hinge



With generous storage and stylish stainless steel design for a timeless look. Perfect for smaller kitchens.

- ActiveSmart™ technology to help keep food fresher for longer by stopping temperature fluctuation
- Spacious bottom freezer with full extension drawer gives easy access to frozen goods.
- Choose which side you'd like your door hinge on to suit your kitchen layout

DIMENSIONS

Height	1715mm
Width	635mm
Depth	695mm

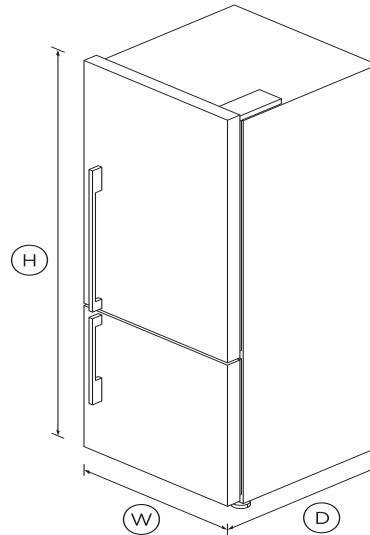

FEATURES & BENEFITS

ActiveSmart™ Foodcare

Every time you open your refrigerator, the temperature around your food changes. ActiveSmart™ foodcare adjusts airflow to create a stable temperature, helping your food stay fresher for longer.

Easy cleaning

No more permanent dirty marks with our EZKleen feature for stainless steel refrigerators. Anti-fingerprint coating means you simply wipe clean any marks. Spill-safe secure glass shelves

easily capture any drips or leaks.

Design quality

Our refrigerators are designed and built using quality materials. We use real stainless steel, and solid glass for shelving as well as in our wine cabinet doors.

Clever energy

Your refrigerator adapts to daily use by cooling and defrosting only when needed. This means it uses the energy it needs without compromising on food care.

Humidity control

Your fruit and veges need different environments. The humidity control slides in each storage bin create a microclimate that helps keep food fresher for longer.

SPECIFICATIONS

Accessories (sold separately)

Joiner kit	819264
Surround Kit (Joined left/right)	Part number 23982
Surround Kit (Left Hand)	23980
Surround Kit (Right Hand)	23981

Capacity

Volume freezer	111L
Volume refrigerator	269L

Consumption

Energy rating	2 ticks
Energy usage	471kWh/year
In-use energy carbon	180.5kgCO2e/year

Features

Adjustable door shelves	4
Adjustable glass shelves	4
Covered door shelves	2
Door alarm	•
Fruit and vegetable bins	2
SmartTouch control panel	•
Stackable bottle holders	2

Sealed system parts only **5 years**

SKU 26346

The product dimensions and specifications in this page apply to the specific product and model. Under our policy of continuous improvement, these dimensions and specifications may change at any time. You should therefore check with Fisher & Paykel's Customer Care Centre to ensure this page correctly describes the model currently available. ? Fisher & Paykel Appliances Ltd 2020

Freezer Features

Bottle chill	•
Door alarm	•
Fast freeze	•
Large plastic bins	•

Performance

ActiveSmart™ Foodcare	•
Adaptive defrost	•
Frost free freezer	•
Humidity control system	•
Noise emissions	42dBA
Noise emissions class	D
Sabbath mode	•

Product dimensions

Depth	695mm
Height	1715mm
Width	635mm

Warranty

Parts and labour	2 years
------------------	----------------



A PEACE OF MIND SALE

24 Hours 7 Days a Week Customer Support

T +65 6741 0777 **W** www.fisherpaykel.com