

48" Series 7 Professional 8 Burner Gas Range, LPG

Professional



A striking addition to your kitchen, with eight powerful gas burners and two gas ovens giving you a combined capacity of 7.7 cu ft.

- Top burner heat of 19,000 BTU, for seriously fast boiling
- Expansive 7.7 cu ft total oven capacity across two oven cavities
- Non-tip full-extension shelves in main cavity for safe removal of hot dishes

DIMENSIONS

Height 35 3/4 - 36 3/4 "

Width 47 7/8 "
Depth 29 1/8 "

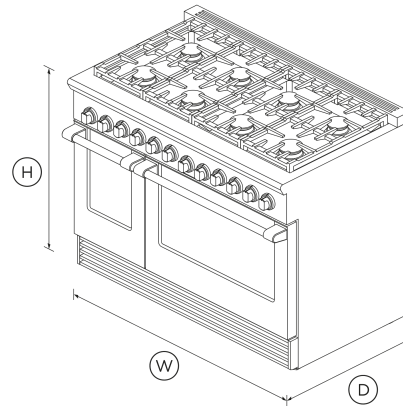

FEATURES & BENEFITS

Cooktop Power

Sealed Dual Flow Burners™ deliver cooktop power up to 23,500 BTU (NG models) for seriously fast boiling right down to a precise 140°F full surface simmer with the gentlest of flames.

Total Control

Precise control across high and low settings is delivered through the halo-illuminated cooktop dials. The ovens have true convection and electronic oven control for precise and consistent temperatures.

Easy To Clean

A sealed cooktop surface coupled with a commercial-style stainless steel finish means your cooktop simply needs a quick wipe to keep it looking good as new.

Instant Visibility

Control dials have halo-illumination glowing white – heating up; orange – temperature reached; red – self-cleaning mode. The oven is illuminated by two powerful incandescent lights.

Cooking Flexibility

The cooktop is designed for easy access to any burner with grates you can smoothly slide pots across. The oven is large enough to hold full size baking sheets.

Consistent Broiling

The Gas Range broiler provides an even heat that covers a very large surface area – perfect for browning a fully loaded oven tray.

SPECIFICATIONS

Accessories (sold separately)

Square handle option AH-R48

Burner ratings

Maximum burner power	19000 BTU
Power back centre	13000BTU
Power back centre (2)	13000BTU
Power back left	13000BTU
Power back right	13000BTU
Power front centre	15000BTU
Power front centre (2)	15000BTU
Power front left	19000BTU
Power front right	19000BTU

Total cooktop power **120000 BTU**

Capacity

Shelf positions (main oven) **5**
 Shelf positions (second oven) **5**

Controls

Electric circuit **3**
 Metal illuminated dials **•**

Gas Requirements

Fitting and pipe **½ NPT, min. 5/8" flex line**
 Supply Pressure (LPG) **11" to 14" W.C**

Main oven features

Broil pan **•**
 Electronic oven control **•**
 Full extension telescopic racks **•**
 Infrared broiler **•**
 Internal light **•**

Main oven functions

Bake **•**
 Broil **•**
 Convection bake **•**
 Number of oven functions **3**

Oven features

Auto re-ignition system **•**

Power Requirements

Amperage **15 A**
 Rated current **15 A**
 Supply frequency **60 Hz**

Product Dimensions

Depth **29 1/8 "**
 Depth (excluding handles) **2918 mm**
 Height **35 3/4 - 36 3/4 "**
 Width **47 7/8 "**

Rangetop features

Sealed range top **•**
 Vent trim included **•**

Recommended Back Guards Ventilation

Combustible situation **BGRV2-3048H**
 Minimum CFM **1200**
 Non combustible situation **BGRV2-3048 / BGRV2-1248**
 Recommended hood **HCB48-12_N (48" Professional Range Hood, Dual Blower)**

Safety

ADA compliant **•**
 Full extension telescopic sliding shelves **•**

Secondary oven features

¾ Extension racks **2**
 Electronic oven control **•**
 Internal light **•**

Secondary oven functions

Bake **•**
 Number of secondary oven functions **2**
 Proof **•**

SKU **71351**

The product dimensions and specifications in this page apply to the specific product and model. Under our policy of continuous improvement, these dimensions and specifications may change at any time. You should therefore check with Fisher & Paykel's Customer Care Centre to ensure this page correctly describes the model currently available. © Fisher & Paykel Appliances Ltd 2020

Other product downloads available at fisherpaykel.com

- [↓](#) DWG
- [↓](#) DXF
- [↓](#) Archicad

- [↓](#) Data Sheet (English)
- [↓](#) Installation Guide (English, Canadian French)
- [↓](#) Planning Guide (English)
- [↓](#) Revit
- [↓](#) Rhino
- [↓](#) Right To Repair Declaration (English, Canadian French)
- [↓](#) SketchUp
- [↓](#) User Guide (English)

Where applicable:

All appliances use energy, and energy usage typically generates carbon emissions. **Fisher & Paykel Appliances' In-use Energy Carbon Emissions Estimate** indicates carbon emissions from a product's in-use energy. This is calculated either annually or per cycle, using the product's market-specific energy label energy consumption data multiplied by the carbon emissions factor for energy in your country or region.

Our In-use Energy Carbon Emissions Estimate is designed to assist customers in making informed purchasing decisions when comparing different Fisher & Paykel products. For example, a heat pump dryer typically has a lower In-use Energy Carbon Emissions Estimate than a vented dryer.



A PEACE OF MIND SALE
24 Hours 7 Days a Week Customer Support
T 1.888.936.7872 W www.fisherpaykel.com