

# 60cm Series 7 Minimal Pyrolytic Oven, 16 Function

Minimal



With refined Minimal styling and generous capacity, this built-in oven helps to ensure that every dish you create is cooked to perfection.

- 16 oven functions including Pastry Bake, Roast, Dehydrate and Rapid Proof
- Even heat circulation with AeroTech™, ideal for multi-shelf cooking
- Pyrolytic self-cleaning function breaks down food residue for an easy clean
- Designed to match our Minimal style family of cooking appliances

## DIMENSIONS

Height	598 mm
Width	596 mm
Depth	565 mm

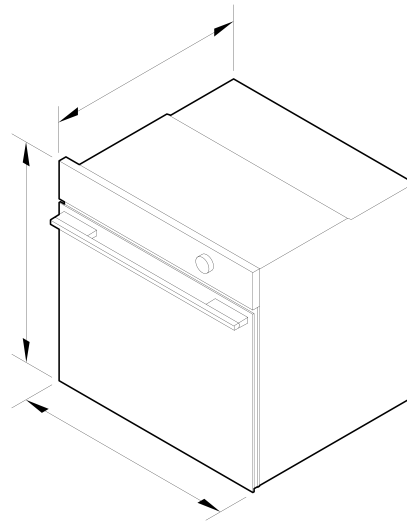

## FEATURES & BENEFITS

### Multi-Function Flexibility

Each function has been perfected to ensure that no matter what you're cooking, you've got the right heat to match. This built-in oven has 16 functions including Pastry Bake, Roast, Aero Broil, Dehydrate and Rapid Proof, allowing you to use a variety of cooking styles.

### Generous Capacity

With a generous 85L total capacity, you can create several perfectly cooked dishes at once using multiple shelves.

### Cook With Confidence

The 2.4" screen provides an intuitive guided cooking experience that helps to deliver perfect results, whether you've been cooking all your life or are just starting out. Cook by food type and allow your oven to guide you through the steps, or change temperature and heat type automatically, depending on your selection.

### Exceptional Performance

Our unique cooking technologies were developed to deliver perfect results. ActiveVent ensures optimized moisture levels, while AeroTech™ circulates heat evenly for a consistent temperature.

### Self-Cleaning

Pyrolytic self-clean breaks down food residue at a very high temperature, leaving a light ash that's easily removed with a damp cloth. The enamel coated side racks don't need to be removed when using this function.

### Complementary Design

Designed to blend seamlessly into the kitchen, this Minimal style oven features subtle textural and tonal contrasts. Available in a black or grey finish to support a considered kitchen design.

### Safe And Sound

The CoolTouch door features triple glazing and a cooling system that ensures it's safe to touch from the outside - protecting both your hands and the surrounding cabinetry.

## SPECIFICATIONS

### Accessories (included)

Full extension sliding shelves	1 set
Grill rack	1 set
Pyrolytic proof shelf runners	•

Roasting dish	1
Smokeless grill tray	1
Step down wire shelf	1
Wired temperature sensor	1

**Capacity**

Shelf positions	6
Total capacity	85 L
Usable capacity	72 L

**Cleaning**

Acid resistant graphite enamel	•
Pyrolytic self-clean	•
Pyrolytic-proof side ladders	•
Removable oven door	•
Removable oven door inner glass	•
Removable side ladders	•

**Connected Features**

Cyber security updates until	11 / 10 / 2028
------------------------------	----------------

**Controls**

Adjustable audio and display settings	•
Audio feedback	•
Automatic cooking/minute timer	•
Automatic pre-set temperatures	•
Celsius/Fahrenheit temperature	•

Delay start	•
Electronic clock	•
Electronic oven control	•
Guided cooking by food types	•
Internal Light	•
Intuitive touchscreen display	•

Multi-language display	•	<b>UK English</b>
Sabbath mode with Mehadrin certification	•	
Smart appliance	•	
Soft close doors	•	
Temperature sensor	•	
True convection oven	•	
Turned stainless steel dials with illuminated halos	•	
Wireless temperature sensor compatible	•	

**Functions**

Air fry	•
Bake	•
Classic bake	•
Dehydrate	•
Fan bake	•
Fan forced	•
Fan grill	•
Grill	•
Number of functions	16
Pastry Bake	•
Pizza bake	•
Pyrolytic self-clean	•
Rapid proof	•
Roast	•

Slow cook	•
Vent bake	•
Warm	•

**Performance**

ActiveVent™ system	•
AeroTech™ technology	•
Automatic rapid pre-heat	•
Grill power	3000 W
Temperature range	35°C - 280°C
Whisper Quiet Cooking	•

**Power requirements**

Amperage	15 A
Rated current	15 A
Supply frequency	50 Hz
Supply voltage	220-240 V

**Product dimensions**

Depth	565 mm
Height	598 mm
Width	596 mm

**Safety**

Balanced oven door	•
Catalytic venting system	•
Control panel key lock	•

- CoolTouch door
- Non-tip shelves
- Safety thermostat

Our In-use Energy Carbon Emissions Estimate is designed to assist customers in making informed purchasing decisions when comparing different Fisher & Paykel products. For example, a heat pump dryer typically has a lower In-use Energy Carbon Emissions Estimate than a vented dryer.



**A PEACE OF MIND SALE**  
**24 Hours 7 Days a Week Customer Support**  
T 1300 650 590 Wwww.fisherpaykel.com

---

SKU 82544

---

The product dimensions and specifications in this page apply to the specific product and model. Under our policy of continuous improvement, these dimensions and specifications may change at any time. You should therefore check with Fisher & Paykel's Customer Care Centre to ensure this page correctly describes the model currently available. © Fisher & Paykel Appliances Ltd 2020

#### Other product downloads available at fisherpaykel.com

- [↓ DWG](#)
- [↓ DXF](#)
- [↓ Installation Guide \(English\)](#)
- [↓ Planning Guide - 60cm Minimal Series 7 \(English\)](#)
- [↓ Revit](#)
- [↓ Rhino](#)
- [↓ SketchUp](#)
- [↓ User Guide \(English\)](#)

#### Where applicable:

All appliances use energy, and energy usage typically generates carbon emissions. **Fisher & Paykel Appliances' In-use Energy Carbon Emissions Estimate** indicates carbon emissions from a product's in-use energy. This is calculated either annually or per cycle, using the product's market-specific energy label energy consumption data multiplied by the carbon emissions factor for energy in your country or region.