



### OVERVIEW

The centrepiece of the outdoor kitchen, this built-in 48" grill takes outdoor cooking to the next level. The new infrared burner produces intense heat and even temperature across the cooking surface, for the perfect sear. With a matching look across all DCS Series 9 products, you can create a stylish, cohesive design for your outdoor kitchen.

### MODELS

48" Series 9 Grill with Infrared Sear Burner, Natural Gas  
BE1-48RCI-N

48" Series 9 Grill with Infrared Sear Burner, LP Gas  
BE1-48RCI-L

### SERIES & STYLE

Series 9  
Professional

### FEATURES

- ① Infrared Sear Burner for incredibly fast searing and perfectly even heat distribution
- ② Secondary cooking space and double-sided grilling grates provide flexibility for any cooking style
- ③ Delivers 25,000 BTU/hr total power per burner and heat control from 150°C to 600°C
- ④ Charcoal smoker tray with the ease of instant gas flame ignition
- ⑤ Intuitive lighting with bright in-hood lights and bezel lit control dials
- ⑥ Easy to lift hood for better access when cooking
- ⑦ Infrared rotisserie burner provides searing heat, while the powerful motor easily turns a 22kg load
- ⑧ Hand-finished in premium stainless steel and built to last
- ⑨ Grease Management System™ reduces flare-ups by channelling grease and oils away when grilling
- ⑩ Wireless Temperature Sensor precisely monitors cooking in real time. (Optional accessory, sold separately)

### ACCESSORIES

- ① Insulation Jacket BGA48-IJS\*

\*insulation jacket is required when installing the grill into combustible materials

**SPECIFICATIONS**

<b>Model No.</b>	BE1-48RCI-N and BE1-48RCI-L
<b>Dimensions</b>	<b>H</b> 696mm x <b>W</b> 1217mm x <b>D</b> 682mm
<b>Electrical</b>	
<b>Supply</b>	120V, 60Hz
<b>Gas - Natural</b>	
<b>Supply</b>	6" to 9" W.C.
<b>Inlet</b>	1/2" female NPT x 3/8" male flare
<b>Gas - LPG</b>	
<b>Supply</b>	12" to 14" W.C.
<b>Inlet</b>	1/2" female NPT x 3/8" male flare

**PRODUCT DIMENSIONS**

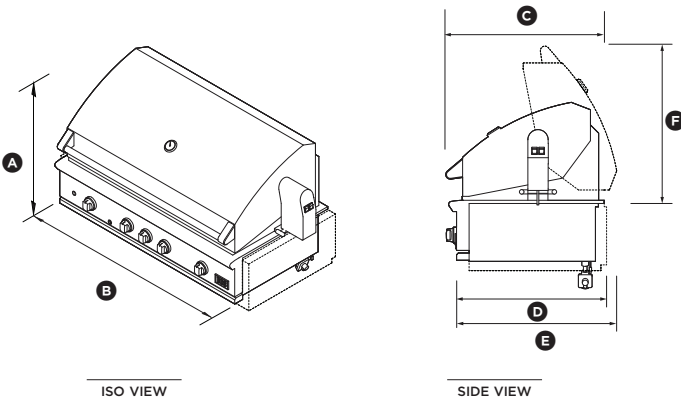

**CAVITY DIMENSIONS: STANDARD INSTALLATION**

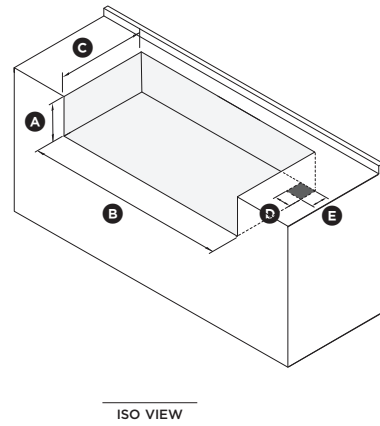

	mm
(A) Overall height	696
Overall height with insulation jacket	725
(B) Overall width	1217
Overall width with insulation jacket	1308
(C) Overall depth	682
(D) Overall depth with insulation jacket*	658
(E) Overall depth when lid is open*	706
(F) Overall height from top of hood to top of countertop	691

	mm
(A) Overall height	257
Overall height with insulation jacket	283
(B) Overall width	1162
Overall width with insulation jacket	1318
(C) Overall depth	578
Overall depth with insulation jacket	578
(D) Overall width connection cutout	102
(E) Overall depth connection cutout	102

\*not including dials or handle