

# Single DishDrawer Dishwasher, Tall, Sanitise

Contemporary



Created with extra height for large dishes and designed to be placed anywhere in your kitchen, for loading dishes with less bending.

- With extra height for taller dishes, and customisable internal shelving
- Six wash programs, as well as additional Quick wash, Sanitise and Extra Dry options

## DIMENSIONS

Height **454 mm**

Width **599 mm**

Depth **573 mm**

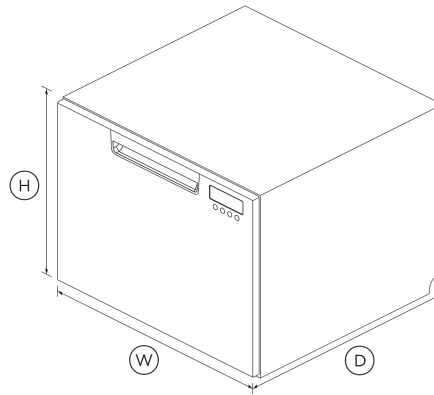

## FEATURES & BENEFITS

### Seamless integration

DishDrawer™ Dishwashers integrate beautifully into any kitchen space. They're designed to match the Fisher & Paykel family of kitchen appliances, with matching handles, premium styling and quality materials.

### Quiet performer

Running at a very low decibel rate, these DishDrawer™ Dishwashers do their job without making a fuss. The combination of intelligent technology and simple mechanics means greater reliability and excellent wash performance.

### Quick, Sanitise and Extra Dry options

The Quick wash modifier delivers a faster wash while maintaining performance. The Sanitise option provides extra protection, killing 99.9% of bacteria\* in the final rinse. The Extra Dry setting is perfect for plastic dishes. \*Certified to NSF/ANSI Standard 184

### Ease of use

DishDrawer™ Dishwashers are as easy to open and close as kitchen drawers and can be conveniently positioned at bench height for ease of loading and minimal bending. Flexible racking allows you to make adjustments to fit in a variety of dishes.

## SPECIFICATIONS

### Accessories (included)

- Cutlery basket
- Knife clip and multipurpose clip

### Capacity and loading

Accommodates round plates up to	<b>310mm</b>
Adjustable height, foldable cupracks	•
Fold down tines	•
Pitch adjustable tines	•
Place settings	<b>7</b>
Place settings	<b>7</b>

### Consumption

Energy rating	<b>3.5 star</b>
Energy usage	<b>136kWh/year</b>
In-use energy carbon emissions estimate	<b>83.0kgCO2e/year</b>

Water consumption (per wash cycle)	<b>6.9L</b>
Water rating	<b>4.5 star (WELS)</b>

**Controls**

Electronic fault/Diagnostic indicator	•
End of cycle beeps	•
Energy saving delay start option of up to 12 hours	•
Keylock	•
Rinse aid indicator light	•
Smart appliance	•

**Features**

Fan assisted drying	•
Flood protection	•
Flow through detergent dispenser	•
Motor type	<b>BLDC</b>
Quiet operation	•
SmartDrive™ technology	•

**Performance**

Noise emissions	<b>42 dBA</b>
-----------------	---------------

**Power requirements**

Amperage	<b>5A</b>
Supply frequency	<b>50Hz</b>
Supply voltage	<b>220 - 240V</b>

**Product dimensions**

Depth	<b>573 mm</b>
Height	<b>454 mm</b>
Width	<b>599 mm</b>

**Wash Program Modifiers**

Extra Dry	•
Quick	•
Sanitise	•
Wash modifiers	<b>3</b>

**Wash Programs**

Delicate	•
Eco	•
Fast	•
Heavy	•
Medium	•
Rinse	•
Wash programs	<b>6</b>

**Water connection**

Water pressure	<b>30kPa - 1000 kPa</b>
Water supply	<b>3/4" BSP (20mm) Connector Water Inlet Hose</b>

SKU	81593
-----	-------

The product dimensions and specifications in this page apply to the specific product and model. Under our policy of continuous improvement, these dimensions and specifications may change at any time. You should therefore check with Fisher & Paykel's Customer Care Centre to ensure this page correctly describes the model currently available. © Fisher & Paykel Appliances Ltd 2020

**Other product downloads available at fisherpaykel.com**

- [↓](#) DWG
- [↓](#) DXF
- [↓](#) Care & Maintenance (English)
- [↓](#) Data Sheet (English)
- [↓](#) First Use (English)
- [↓](#) Installation Guide (English)
- [↓](#) Installation Guide (English)
- [↓](#) Revit
- [↓](#) Rhino
- [↓](#) SketchUp
- [↓](#) Installation Video

**Where applicable:**

All appliances use energy, and energy usage typically generates carbon emissions. **Fisher & Paykel Appliances' In-use Energy Carbon Emissions Estimate** indicates carbon emissions from a product's in-use energy. This is calculated either annually or per cycle, using the product's market-specific energy label energy consumption data multiplied by the carbon emissions factor for energy in your country or region.

Our In-use Energy Carbon Emissions Estimate is designed to assist customers in making informed purchasing decisions when comparing different Fisher & Paykel products. For example, a heat pump dryer typically has a lower In-use Energy Carbon Emissions Estimate than a vented dryer.



**A PEACE OF MIND SALE**

24 Hours 7 Days a Week Customer Support

T 1300 650 590 W [www.fisherpaykel.com](http://www.fisherpaykel.com)