



Professional outdoor grill
BGB36 and BGB48 models

**Installation instructions
and User guide**

A MESSAGE TO OUR CUSTOMERS

Thank you for selecting this DCS by Fisher & Paykel Professional “BGB” Series Grill. Because of these appliances’ unique features we have developed this manual. It contains valuable information on how to properly install, operate and maintain your new appliance for years of safe and enjoyable cooking.

To help serve you better, please fill out and submit your Product Registration by visiting our local website listed on the back cover. In addition, keep this guide handy, as it will help answer questions that may arise as you use your new appliance.

See section ‘Service’ for Customer Care contact details.

NOTE: Please write the Model, Serial, and Part Numbers on this page for reference (can be found on the inside, right side panel behind the drip pan handle).

MODEL NUMBER _____ SERIAL NUMBER _____ PART NUMBER _____

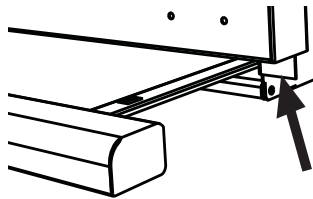

NOTE: Inspect the product to verify that there is no shipping damage. If any damage is detected, call the shipper and initiate a damage claim. DCS by Fisher & Paykel is not responsible for shipping damage.

DO NOT discard any packing material (box, pallet, straps) until the unit has been inspected.

WARNING!

Do not try lighting this appliance without reading the “Lighting Instructions” section of this manual. Improper installation, adjustment, alteration, service or maintenance can cause property damage, injury or death. Read the installation, operating and maintenance instructions thoroughly before using, installing or servicing this equipment. This outdoor cooking gas appliance is not intended to be installed in or on recreational vehicles, boats or in a non-ventilated room. For outdoor use only.

WARNING

1. Do Not store or use gasoline or any other flammable vapours and liquids in the vicinity of this or any other appliance.
2. An LPG cylinder not connected for use shall not be stored in the vicinity of this or any other appliance.

DANGER

What To Do If You Smell Gas:

1. Shut off gas to the appliance.
2. Extinguish any open flames.
3. Open hood.
4. If odour continues, keep away from the appliance and immediately call your gas supplier or your fire department.

PLEASE RETAIN THIS MANUAL FOR FUTURE REFERENCE.

TABLE OF CONTENTS

SAFETY PRACTICES & PRECAUTIONS	3
GRILL MODELS	7
INSTALLATION	
Locating Grill / Built-in Clearances	8
Built-in Construction Details	12
Gas Hook-up	13
Leak Testing	18
Burner Adjustment	19
Radiant Assembly	20
Griddle Plate	21
Installer Checklist	22
USING THE GRILL	
Lighting Instructions	24
Grilling	25
USING THE ROTISSERIE	28
CARE & MAINTENANCE	32
TROUBLESHOOTING	41
SERVICE	42
WARRANTY	43

SAFETY PRACTICES & PRECAUTIONS

IMPORTANT SAFETY NOTICE!

Certain Liquid Propane dealers may fill liquid propane cylinders for use in the grill beyond cylinder filling capacity. This “Overfilling” may create a dangerous condition.

“Overfilled” cylinders can build up excess pressure. As a safety device, the cylinder pressure relief valve will vent propane gas vapour to relieve this excess pressure. This vapour is combustible and therefore can be ignited. To reduce this danger, you should take the following safety precautions:

1. When you have your cylinder filled, be sure you tell the supplier to fill it to no more than 3/4 (75%) of its total capacity.
2. If you own or use a spare cylinder, or have a disconnected cylinder, you should NEVER store it near or under the grill/cart unit or heat box, or near any other ignition or heat source. A sticker with this warning is provided with the grill to remind you, your family and all others who may use your BBQ grill of these safety precautions. Install this sticker close to your barbecue grill in a visible location that is not exposed to the elements or extreme heat.
3. Do not store a full cylinder in direct sunlight.

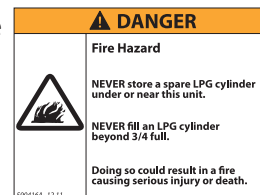

Sticker

WARNING!

Do not try lighting this appliance without reading the “LIGHTING INSTRUCTIONS” section of this manual. This grill is for outdoor use only.

WARNING!

Push and hold the igniter button, turn the selected burner knob to “SEAR”. If burner does not light in 4 to 5 seconds turn knob “OFF” and wait 5 minutes before trying again for any accumulated gas to dissipate.

WARNING:IMPORTANT!

Before each use, inspect the gas supply piping or hose prior to turning the gas “on”. If there is evidence of cuts, wear, or abrasion, it must be replaced prior to use.

Never leave the appliance unattended during use.

- This grill must be installed according to these instructions and in compliance with the requirements of AS/NZS 5601.1:2010, local authority, gas, electricity, and any other statutory regulations. Failure to install the product correctly could invalidate any warranty or liability claims.
- Refer to AS/NZS 5601.1:2010 for pipe sizing details.
- Begin by ensuring proper installation and servicing. Follow the installation instructions within this manual. Have your grill installed by a qualified installer. Have the installer show you where the gas supply shut-off valve is located so that you know where and how to shut off the gas to the grill. If you smell gas, your installer has not done a proper job of checking for leaks. If the connections are not perfectly sealed, you can have a small leak and therefore a faint gas smell. Finding a leak is not a “do-it-yourself” procedure. Some leaks can only be found with the burner control in the “ON” position and this must be done by a qualified gas fitter.
- Children should not be left alone or unattended in an area where the grill is being used. Never allow them to sit, stand or play on or around the grill at any time. When in use, portions of the grill get hot enough to cause severe burns.
- Do not store items of interest to children around or below the grill, in the cart or masonry enclosure. Never allow children to crawl inside a cart or enclosure.
- Never attach or disconnect an LPG cylinder, or move or alter gas fittings when the grill is in operation or is hot.
- Use caution when closing the hood, especially if there are children around. Check that the path of the hood is clear, as its weight could cause injury to hands or fingers caught under it.
- Clean and perform general maintenance on the grill twice a year. Watch for corrosion, cracks, or insect activity. Have a qualified gas fitter check the regulator, hoses, burner ports, air shutter, and venturi/valve section carefully. Always turn off gas at the source (cylinder or supply line) prior to inspecting parts.



SAFETY PRACTICES & PRECAUTIONS

- After a period of storage or non-use (such as over the winter), the gas grill should be checked for gas leaks, deterioration, proper assembly, and burner obstructions before using.
- Never let clothing, pot holders or other flammable materials come in contact with or get too close to any grate, burner or hot surface until it has cooled. Fabric may ignite and result in personal injury.
- Do not heat unopened food containers as a build-up of pressure may cause the container to burst.
- Always use a covered hand when opening the grill hood and only do so slowly to allow heat and steam to escape.
- Never lean over an open grill. When lighting a burner, always pay close attention to what you are doing. Be certain you are pushing the ignition button when you attempt to light the grill.
- After lighting burners, make sure burners are operating normally (see section 'Burner adjustment').
- When using the grill, do not touch the grill, grate, or immediate surrounding area as these areas become extremely hot and could cause burns.
- Grease is flammable. Let hot grease cool before attempting to handle it. Avoid letting grease deposits collect in the drip pan. Clean often.
- Never operate the grill without a grease tray.
- Do not use aluminium foil to line drip pans or grill grates or radiants. This can severely upset combustion air flow or trap excessive heat in the control area. The result of this can be melted knobs or damaged ignition components.
- The prongs of the rotisserie forks are very sharp. Take care when unpacking, assembling, or handling the rotisserie to avoid injury.
- Do not operate with a damaged cord or plug or after the appliance malfunctions or has been damaged in any manner. Contact the manufacturer for repair.
- Do not let the cord hang over the edge of a table or touch hot surfaces.
- Do not use an outdoor cooking appliance for purposes other than intended.
- This appliance is not intended for use by persons (including children) with reduced physical, sensory or mental capabilities, or lack of experience and knowledge, unless they have been given supervision or instruction concerning use of the appliance by a person responsible for their safety.

SAFETY PRACTICES & PRECAUTIONS

For personal safety, wear proper apparel. Loose fitting garments or sleeves should never be worn while using this appliance. Some synthetic fabrics are highly flammable and should not be worn while cooking. Only certain types of glass, heat-proof glass ceramic, earthenware, or other glazed utensils are suitable for grill use. Use of these types of materials may break with sudden temperature changes. Use only on low or medium heat settings according to the manufacturer's directions.

WARNING!

Spiders and insects can nest in the grill burners, causing gas not to flow through the burner. The gas will flow from the front of the burner into the control panel. This is a very dangerous condition which can cause a fire to occur behind the valve panel, thereby damaging the grill components and making it unsafe to operate.

WARNING!

Keep the area surrounding the grill free from combustible materials, trash, or combustible fluids and vapours such as gasoline or charcoal lighter fluid. Do not obstruct the flow of combustion and ventilation air.

WARNING!

Never use the grill in windy conditions. If located in a consistently windy area (oceanfront, mountaintop, etc.) a wind break will be required. Always adhere to the specified clearances as defined in the "INSTALLATION" section of this manual.

GRILL PLACEMENT

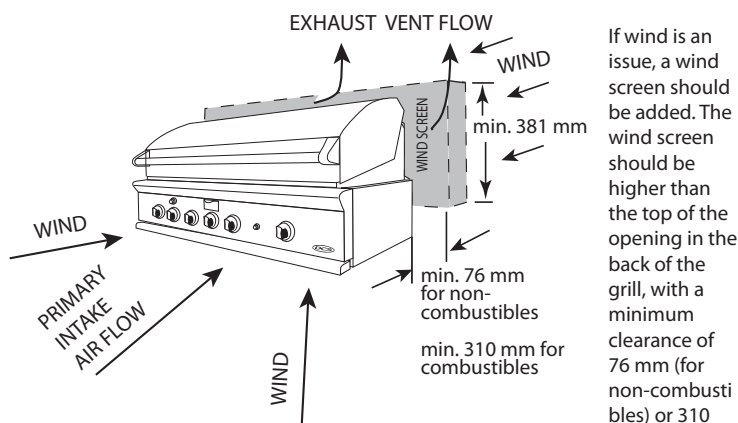
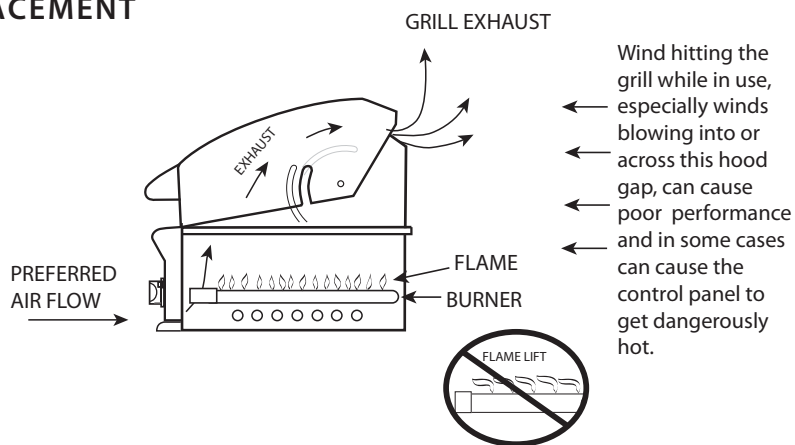

SAFETY PRACTICES & PRECAUTIONS

- When using the side burners always use flat bottomed pans which are large enough to cover the side burner. Adjust the flame so that it heats only the bottom of the pan to avoid ignition of clothing. Position handles inward away from open edges of the unit to avoid burns associated with unintentional spillovers. Hold the handle of the pan to prevent movement of it when turning or stirring food. For proper lighting and performance of the burners keep the ports clean. It is necessary to clean periodically for optimum performance.
- This professional outdoor grill delivers extreme heat. Take care during and after use, as all surfaces may be hot.
- Clean the grill with caution. Avoid steam burns; do not use a wet sponge or cloth to clean the grill while it is hot. Some cleaners produce noxious fumes or can ignite if applied to a hot surface.
- Be sure all grill controls are turned off and the grill is cool before using any type of aerosol cleaner on or around the grill. The chemical that produces the spraying action could, in the presence of heat, ignite or cause metal parts to corrode.
- Do not use the grill for cooking excessively fatty meats or products which promote flare-ups.
- Never grill without the drip pan and grease tray in place and the drip pan pushed all the way to the back of the grill. Without it hot grease could leak downward and produce a fire or explosion hazard.
- Do not operate the grill under unprotected combustible construction. Use only in well ventilated areas. Do not use in buildings, garages, sheds, breezeway, covered structure or other such enclosed areas. This unit is for outdoor use only. Always ensure adequate ventilation for the grill. Never block any ventilation openings.
- If a cart unit is stored indoors, ensure that it is cool, fold the side shelf down, then push, never pull, the grill and never push or pull on the side shelves. If LPG, the cylinder must be unhooked and the LPG cylinder stored outside in a well ventilated area, out of reach of children.
- If grill is mounted on a mobile cart: do not remove castor wheels from cart, as resting the cart directly on its base will block ventilation openings, causing a hazardous situation. Keep ventilation openings on side walls and base of cart unobstructed at all times.
- Never use the grill in a windy area.
- Do not use charcoal or lighter fluid in the outdoor grill. Charcoal or similar combustible fuels must not be used with the appliance.
- Keep any electrical supply cord, or the rotisserie motor cord away from the heated areas of the grill and water (pools, fountains, puddles).
- Never use a dented or rusty LPG cylinder. Keep the ventilation openings of the cylinder enclosure free and clear from debris.
- Use only dry potholders; moist or damp potholders on hot surfaces may cause burns from steam. Do not use a towel or bulky cloth in place of potholders. Do not let potholders touch hot portions of the grill or burner grate.
- Have an ABC rated Fire Extinguisher accessible – never attempt to extinguish a grease fire with water or other liquids.
- To avoid burns when cooking, use long handled BBQ tools.
- Do not move the appliance during its use.
- Do not locate the outdoor grill in an inclined plane. Be sure to lock the castor wheels before operating the unit.
- **This unit is for outdoor use only!** Do not operate in enclosed areas. This could result in carbon monoxide build-up which would result in injury or death.
- When using a grill, be sure that all parts of the unit are firmly in place and that the grill is stable (can't be tipped over).
- To put out flare-ups, adjust the controls to lower the temperature.
- Open the hood before lighting a grill burner or the rotisserie burner.
- When cooking with the hood closed, use the LOW setting only.
- Do not use the rotisserie burner in combination with any grill burner.
- This outdoor cooking gas appliance is not intended to be installed in or on recreational vehicles, trailers and/or boats.

GRILL MODELS



BGB48-BQAR



BGB48-BQR

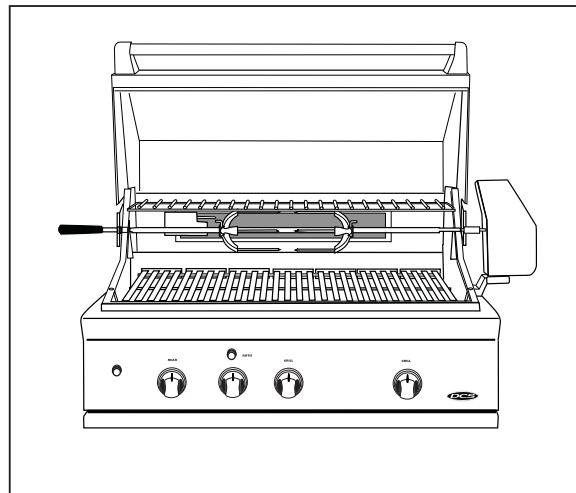

BGB36-BQAR

INSTALLATION

LOCATING GRILL/BUILT-IN CLEARANCES

Tools required: Phillips screwdriver.

Important!

Before installation, remove shipping brackets from the grill. To do so, loosen the 4 screws on the bottom sides of the grill which hold the brackets to the grill. Slide the shipping brackets off and retighten the screws.

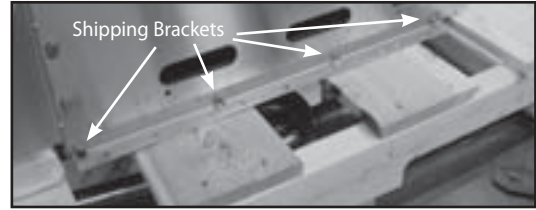

FIG. 1

Remove all internal packaging and adhesive residue. To remove stubborn residue, use rubbing alcohol or a commercially available adhesive remover.

Packing elements (i.e. plastic bags, polystyrene foam, nails, packing straps, etc.) should not be left around within easy reach of children, as these may cause serious injuries.

LOCATION:

When determining a suitable location take into account concerns such as exposure to wind, proximity to traffic paths and keeping any gas or electrical supply lines as short as possible and away from heat sources. Locate the grill only in a well ventilated area. Do not build the grill under overhead unprotected combustible construction. Never locate the grill in a building, garage, breezeway, shed or other such enclosed areas. See following page for definition and illustration of outdoor areas. During heavy use, the grill will produce a lot of heat and smoke. Ensure there is adequate area for it to dissipate.

If locating the grill in a windy area, try to locate the grill so the prevailing wind will blow air at the front of the grill as shown in Fig. 02. This will assist the grill in venting hot air thru the back of the grill. In addition, this will help keep any smoke from blowing at someone who is cooking on the grill. If you have to locate the grill in a windy area where the prevailing wind is at the rear of the grill, a windbreak must be installed. The windbreak should be made such that it will block wind from entering the exhaust vent in the rear of the unit as shown in Fig. 02. Location of the windbreak relative to rear of the grill must adhere to the clearances specified for combustible or non-combustible construction as defined in these instructions. Refer to following pages.

As a high-performance gas appliance, your grill requires significant amounts of air to support the combustion process. Your grill is designed to take air in through the valve panel area, and send the exhaust products out through the exhaust gap at the rear of the hood. Using your grill in windy conditions can disrupt the proper flow of air through your grill, leading to reduced performance, or in certain severe cases, causing heat buildup in the valve panel area. This can lead to problems such as having the knobs melt, or burn hazards when the valve panel surfaces become too hot to touch.

During high wind conditions, it is best if you don't use your grill. If you live in an area that is subject to frequent high winds, or a steady directional wind, then the installation of a suitable windbreak may be advised. If you have a grilling cart, it is best to position the unit so the prevailing wind blows into the valve panel, thus supporting the proper airflow. Winds hitting the back of the grill directly are the most likely to cause problems, although wind blowing along the exhaust gap in the rear can also be problematic.

Please note that damage to your grill resulting from use in windy conditions, such as melted knobs or igniter wires, or valve panel discoloration from heat build-up, are excluded from warranty coverage.

GRILL PLACEMENT

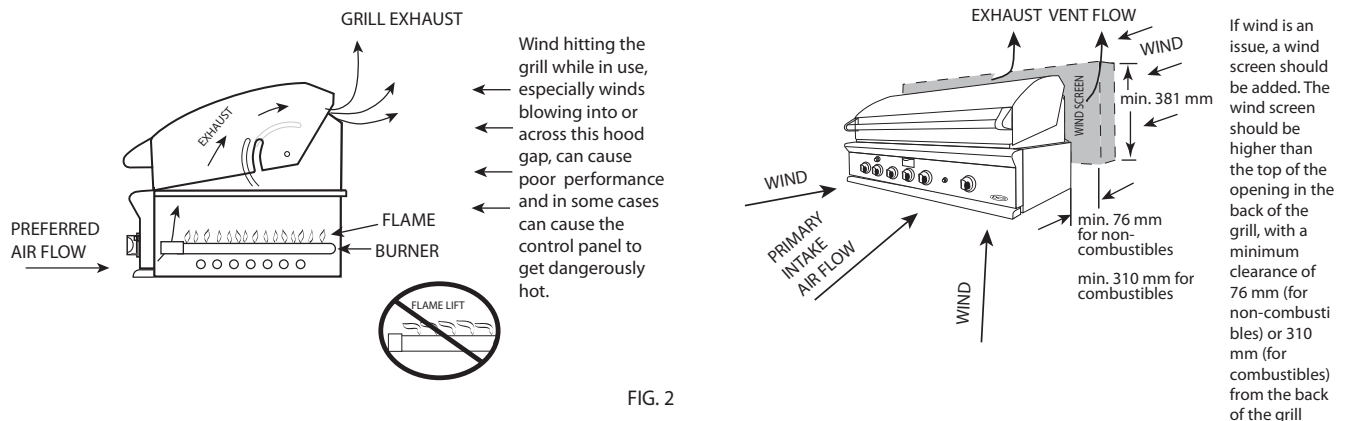

FIG. 2

Important!

Gas fittings, regulator, and installer supplied shut-off valves must be easily accessible.

INSTALLATION

LOCATING GRILL/BUILT-IN CLEARANCES

This appliance shall only be used in an above ground open-air situation with natural ventilation, without stagnant areas, where gas leakage and products of combustion are rapidly dispersed by wind and natural convection.

Any outdoor enclosure in which the appliance is used shall comply with one of the following:

- An enclosure with walls on all sides, but at least one permanent opening at ground level and no overhead cover. See Fig.3.
- Within a partial enclosure that includes an overhead cover and no more than two walls. See Figs. 4 & 5.
- Within a partial enclosure that includes an overhead cover and more than two walls, the following shall apply:
 - At least 25% of the total wall area is completely open and
 - At least 30% of the remaining wall area is open and unrestricted. See Figs. 6 & 7.
- In the case of balconies, at least 20% of the total of the side, back and front wall areas shall be and remain open and unrestricted.

The following diagrams provide a diagrammatic representation of outdoor areas. Rectangular areas have been used in these figures - the same principles apply to any other shaped area.

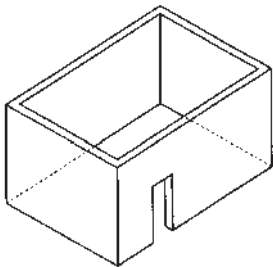

Fig. 3 - Enclosure with walls on all sides but no overhead cover.

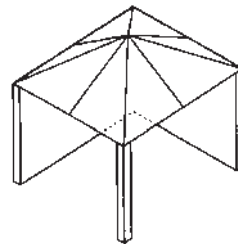
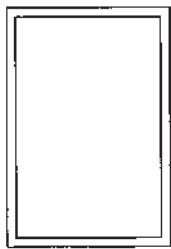

Fig. 4 - Partial Enclosure with overhead cover and no more than two walls.

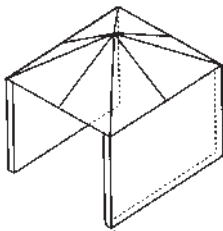
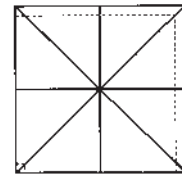

Fig. 5 - Partial Enclosure with overhead cover and no more than two walls.

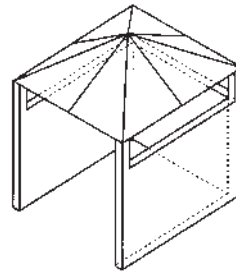
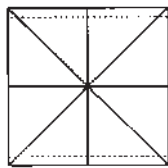

Fig. 6 - Open side at least 25% of total wall area. 30% or more in total of the remaining wall area is open and unrestricted.

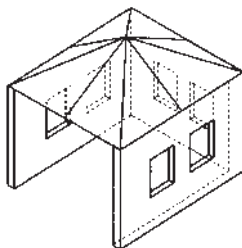
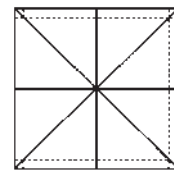
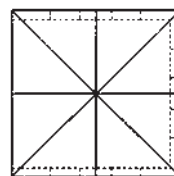

Fig. 7 - Open side at least 25% of total wall area. 30 percent or more in total of the remaining wall area is open and unrestricted.



INSTALLATION

LOCATING GRILL/BUILT-IN CLEARANCES

Clearances to Non-Combustible Construction*:

A minimum of 76 mm clearance from the back of the grill to non-combustible construction is required for the purpose of allowing the hood to open fully. It is desirable to allow at least 153 mm rear and side clearance to non-combustible construction above the cooking surface for counter space. If you'll be using the rotisserie option, the space is essential for motor and skewer clearance. The grill can be placed directly adjacent to non-combustible construction below the cooking surface. (Fig. 8)

Clearances to Non-Combustible Construction*

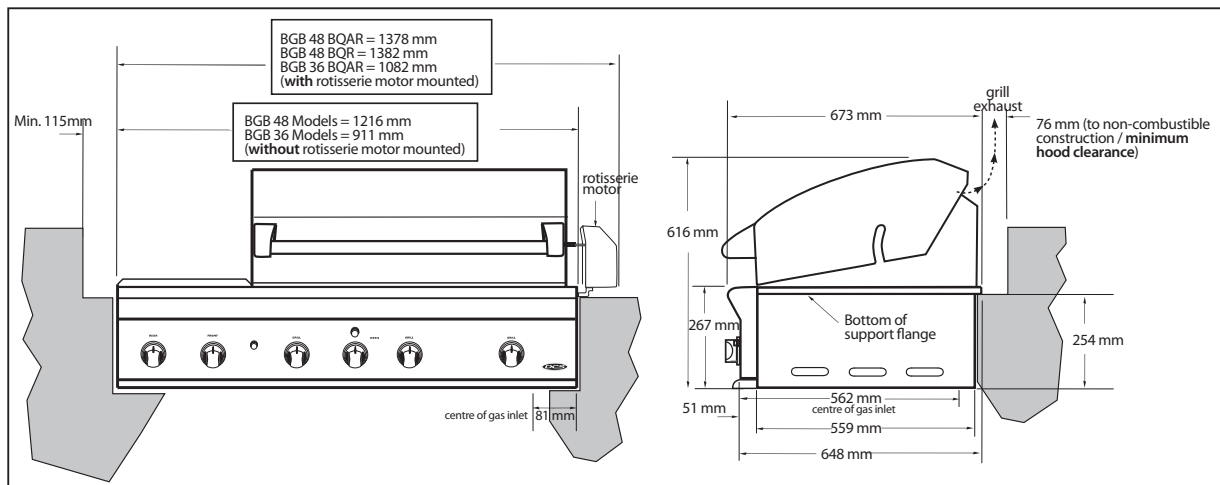

FIG. 8

! WARNING!

Failure to maintain required clearances creates a fire hazard that may result in property damage or serious personal injury. *We recommend installing the Grill as far away from combustible surfaces as possible.*

! WARNING!

The BGB Grill is designed to function in an open area. Recommended minimum clearances should be maintained to all surfaces (combustible and noncombustible) for optimum performance. Noncombustible material within the minimum clearance area could result in discoloration or deterioration.

! WARNING!

If a noncombustible material such as stucco is covering a combustible material such as wood, the minimum clearance distance needs to be held to the wood. The presence of a noncombustible material inside the clearance zone does not eliminate the minimum clearance zone to combustible material.

* **DEFINITION OF NONCOMBUSTIBLE MATERIAL** - Material which is not capable of being ignited and burned, such as materials consisting entirely of, or a combination of, steel, iron, brick tile, concrete, slate, and plaster.

Clearances to Combustible Construction**:

Minimum of 310 mm from the sides and rear of grill must be maintained to adjacent vertical combustible construction, above the counter top level. You should take in account that there is a large volume of heat, and smoke will exhaust from the rear of the grill. This may discolor or damage unprotected areas (Fig. 04). Do not install under unprotected combustible construction without using a fire safe ventilation system.

A 310 mm minimum clearance must be maintained under the counter top to combustible construction. The clearance can be modified by a use of an insulated jacket.

INSTALLATION

LOCATING GRILL/BUILT-IN CLEARANCES

Clearances to Combustible Construction**

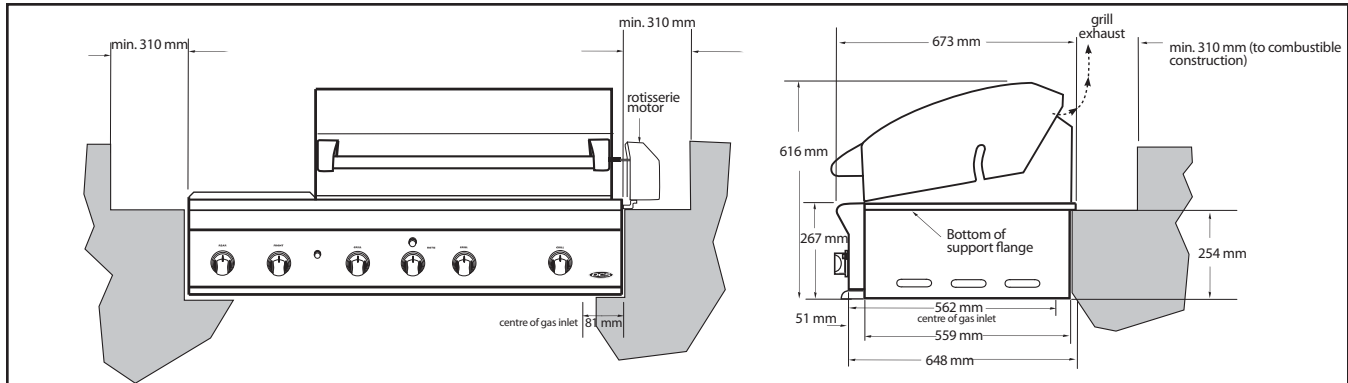

FIG. 9

**** DEFINITION OF COMBUSTIBLE MATERIAL** - Any materials of a building structure or decorative structure made of wood, compressed paper, plant fibers, vinyl/plastic or other materials that are capable of transferring heat or being ignited and burned. Such material shall be considered combustible even though flame-proofed, fire-retardant treated or surface-painted, or plastered.

Important!

It is required that a minimum of 3 x 65 cm² of ventilation opening be provided for both the left and right sides, as well as the back of enclosure (Fig. 10), in order to safely dissipate unburned gas vapours in the event of a gas supply leak.

WARNING!

Note specific built-in enclosure ventilation requirements. See text and Fig. 10.

GENERAL

The grill is designed for easy placement into built-in masonry enclosures. For non-combustible applications the grill drops into the opening shown in Fig. 10 and hangs from its side flanges. A deck is not required to support it from the bottom. When using the insulated jacket in a combustible enclosure application, see the bottom of Fig. 10. The insulation jacket assembly must be supported from the bottom by a ledge on each side and back or a solid deck.

A carpenter's "spirit level" should be used to assure that the unit is level both front-to-back and side-to-side. If it is not level, burner combustion may be erratic or the unit may not function efficiently for grease flow. If the floor is uneven or has a decided slope, re-leveling may be required after each moving of a freestanding unit.

INSULATED JACKET:

WARNING!

Installing this product into a combustible enclosure without an insulated jacket could result in fire, property damage and personal injury.

If the grill is to be placed into a combustible enclosure, an approved insulated jacket is necessary. Insulated jackets are available from your dealer. Use only the DCS by Fisher & Paykel insulated jacket which has specifically been designed and tested for this purpose. Review the detail drawing shown (Fig. 10) and take into account the provisions shown for gas line hook-up clearance in the right rear corner. It is required that ventilation holes are provided in the enclosure to eliminate the potential build-up of gas in the event of a gas leak. The supporting ledges or deck must be level and flat and strong enough to support the grill and insulated jacket. The counter should also be level.

INSTALLATION

BUILT-IN CONSTRUCTION DETAILS

Important!

- Providing ventilation openings as per the diagrams below is MANDATORY.
- Providing an access opening from the front is MANDATORY. The opening must be large enough to allow easy access to the cylinder valve or shut-off valve for the purposes of shutting gas off to the appliance. If gas supply is via cylinder, the opening must be large enough to allow easy placement and removal of the cylinder too. A custom door may be fitted over the opening, but the user should be able to open the door at all times.

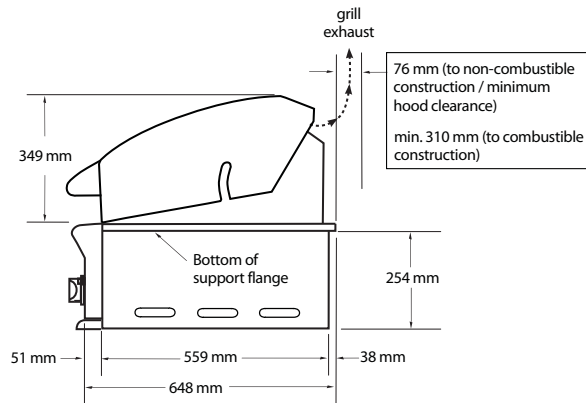

Standard layout for non-combustible enclosure:

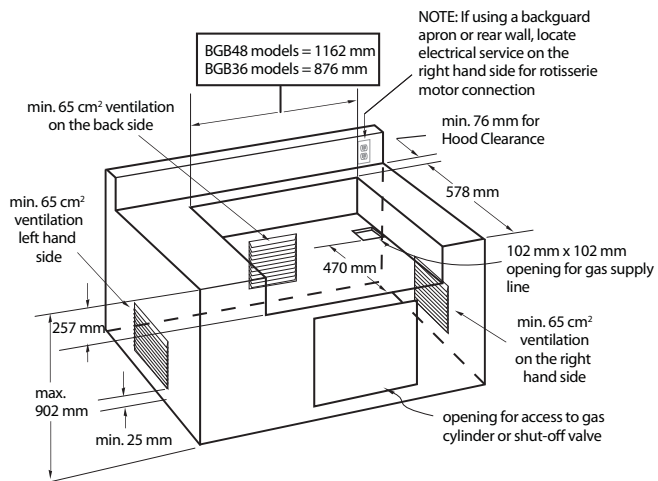

Layout for insulated jacket only - combustible enclosure:

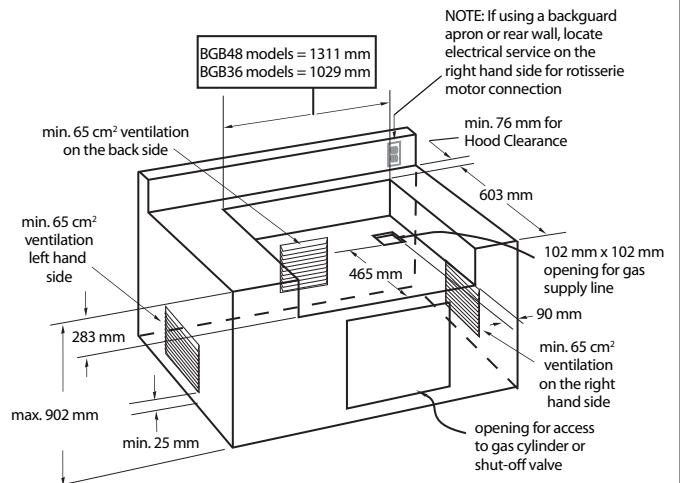

⚠ WARNING!

If installing the grill into a non-combustible enclosure, all combustible construction must still be outside the 310 mm clearance zone. If your island is made of stucco over the top of wooden studs, the wood can not be inside the 310 mm clearance zone to combustible, even though the stucco is what is touching the grill area.

INSULATED JACKET	
Model	Part No.
BGB36	85142
BGB48	85143

FIG. 10

INSTALLATION

GAS HOOK-UP

GAS REQUIREMENTS

Verify the type of gas supply to be used, either natural or LPG, by checking the gas type label on rear panel of the unit and the serial label behind the drip pan handle on the right-hand side. For gas consumption data, see the rating label on the rear panel of the unit. Never connect an unregulated gas line to the appliance. You must use the gas regulator provided with the unit, even if the supply is controlled.

If the unit is being connected to a reticulated gas supply, an installer-supplied gas shut-off valve must be installed in an easily accessible location. All installer supplied parts must conform to local codes, or in the absence of local codes, with the requirements of AS/NZS 5601.1:2010 and any other applicable statutory regulations.

All pipe sealants must be an approved type and resistant to the actions of LPG gases. Never use pipe sealant on flare fittings. All gas connections should be made by a qualified gas fitter and in accordance with local codes and ordinances. In the absence of local codes, the installation must comply with the requirements of AS/NZS 5601.1:2010 and any other applicable statutory regulations. Gas conversion kits are available from Customer Care. See section 'Service' for contact details. When ordering gas conversion kits, have the model number, and the type of gas (natural or LPG) from your grill.

The appliance and its individual shut-off valve must be disconnected from the gas supply piping system during any pressure testing of that system at test pressures in excess of 3.5 kPa (1/2 PSIG). The appliance must be isolated from the gas supply piping system by closing its individual manual shut-off valve during any pressure testing of the gas supply piping system at test pressures equal to or less than 3.5 kPa (1/2 PSIG).

NATURAL GAS HOOK UP:

Important!

THIS TYPE OF CONNECTION SHOULD BE PERFORMED BY A CERTIFIED OR LICENSED GAS FITTER ONLY.

WHERE THREADS ARE USED FOR CONNECTION TO THE APPLIANCE, ALL UNION MATING SURFACES SHALL BE COMPATIBLE AND COMPLY WITH AS ISO 7.1 OR AS 1722.2

Connection: Grills set for use with Natural gas come with an NG regulator assembly which has a short section of hose already connected. The regulator has a test point. The regulator assembly is not connected to the appliance. A certified gas fitter needs to connect the appliance to the gas supply. Shut-off valve and Gas fittings for rigid piping connection are not supplied with the appliance -- they must be provided by the installer.

For built-in installation with connection to Natural Gas:

1. Attach regulator hose assembly to the appliance using the 3/8" SAE 45 Flare connection.
2. Plumb from the female 1/2" BSP side of the regulator to gas supply.
3. Do leak test.
4. After the connection is completed, turn the shut-off valve on and turn the burner control valves on the unit to the "HI" position for about 20 seconds to allow the air in the system to purge, turn valves off and wait 5 minutes before attempting to light the burners.

For units mounted on a mobile cart and being connected to a reticulated supply of Natural gas, and where a quick-connect device is used, ensure that:

- The quick-connect device is certified to AS4627 and the gas hose assembly is certified to AS/NZS 1869;
- Limited flexibility connectors is certified to AS 4631.
- The gas fittings and hose assembly are compatible with the gas supply system and is able to deliver the maximum gas rating requirement of the DCS Outdoor Grill;
- All gas installation works are carried out in accordance the the AS/NZS Gas Installations Standard AS5601 and other applicable Standards; and
- Verify that connections are leak tested.

INSTALLATION

GAS HOOK-UP

NATURAL GAS HOOK UP CONT:

Important!

Where the appliance is intended to be permanently connected to a reticulated supply of gas, the appliance inlet connection shall have a thread in accordance with AS ISO 7.1

For grills mounted on a mobile cart and being connected to a reticulated supply of Natural gas, the installer must ensure that a restraining device that is no longer than 80% of the length of the hose is fitted with an eyebolt within 50mm of an external quick connect device, (as required by AS/NZS 5601.1:2010) in order to prevent tension on the flexible hose in case the cart should move during use. Quick connect devices should be certified to AS4627 and Gas hose assemblies should be certified to AS/NZS 1869.

Operating pressure: 1 kPa **Supply pressure:** 1.25 kPa to 3.5 kPa. If in excess of 3.5 kPa, a step down regulator is required. Check with your local gas utility company or local codes for instructions on installing gas supply lines. Be sure to check on type and size of run (refer to AS/NZS 5601.1:2010 for pipe sizing details), and how deep to

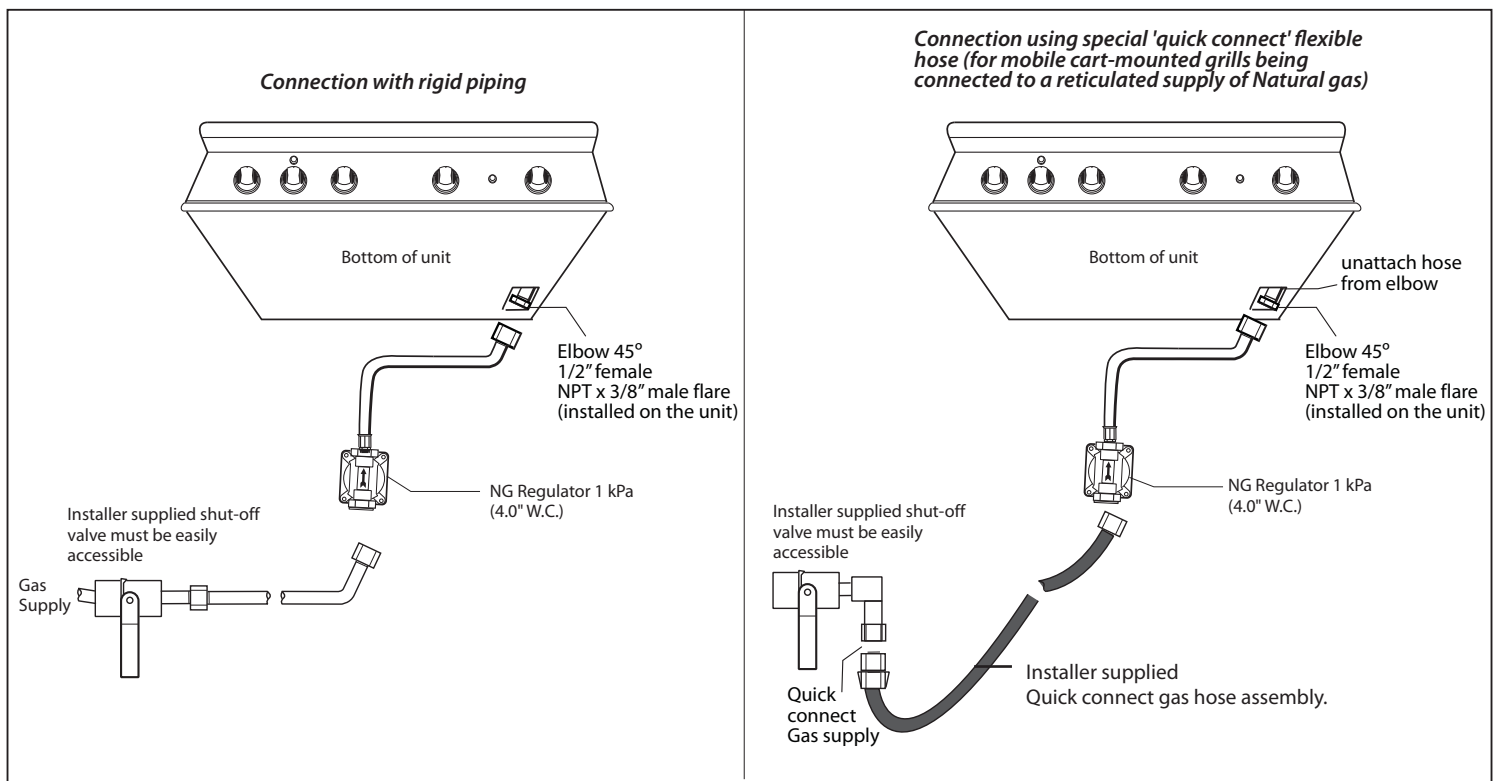

FIG. 11 Natural Gas

bury the line. If the gas line is too small, the grill will not function properly. Any joint sealant used must be an approved type and be resistive to the actions of LPG gases.

CHECKING THE GAS PRESSURE

1. Turn off the gas supply.
2. Connect the pressure gauge to the pressure test point. This can be done by either removing the test point screw on the NG regulator or by removing one of the burners and measuring the test point pressure at the injector.
3. Once the gauge is in position, turn the gas supply on.
4. Ignite all grill burners and turn the knob to the "HIGH" position. Check that the reading measures 1.00 kPa for Natural Gas. If not, adjust the regulator to obtain the stated pressure.
5. Once the pressure is set, switch off the burner, turn off the gas supply, and disconnect the pressure gauge.
6. Ensure the Grill is returned to its normal operating state. Replace the screw in the NG regulator, or replace the burner if it has been removed. Perform a gas leak check on all gas connections to make sure there are no gas leaks at the test point or at any point in the connection to the inlet manifold.

INSTALLATION

GAS HOOK-UP

LPG GAS HOOK UP

Grills set for use with LPG gas come equipped with a high capacity hose/regulator assembly for connection to a standard 9 kg LPG POL cylinder. The LPG cylinder is not included.

Connection: 1/2" NPT male with a 3/8" Flare adapter (included). LPG Hose with a POL fitting and fittings are included. **Operating pressure:** 2.75 kPa. Maximum supply pressure: 1750 kPa.

CAUTION!

Before connecting LPG cylinder to regulator, check that all knobs are in the OFF position and open grill hood.

To connect the LPG regulator/hose assembly to the cylinder/valve assembly, first make sure the main valve on the cylinder is completely closed. You should always turn off the LPG cylinder main valve (Fig. 12) after each use and during transport of the cylinder or unit. Insert the regulator inlet into the cylinder valve and turn clockwise until the coupler tightens up. **Do not overtighten the coupler.** Turn the main cylinder valve on and turn the burner control valves on the unit to the "HI" position for about 20 seconds to allow the air in the system to purge, turn valves off and wait 5 minutes before attempting to light the burners.

To disconnect the coupler, first make sure the main cylinder valve is turned off. Grasp the coupler and turn counter clockwise. The inlet will then disengage. Remove the inlet from the cylinder valve opening if it has not already done so when it disengaged. Your local LPG filling station should be equipped with the proper equipment to fill your cylinder.

LPG CYLINDER REQUIREMENTS:

A dented or rusty LPG cylinder may be hazardous and should be checked by your LPG supplier. The cylinder that is used must have a collar to protect the cylinder valve. Never use a cylinder with a damaged valve. Always check for leaks after every LPG cylinder change. The LPG gas cylinder must conform to AS2030.1:2009 and designed for use with a POL fitting only. Do not change the regulator/hose assembly from that supplied with the unit. The cylinder must be provided with a shut-off valve terminating in an LPG gas supply cylinder valve outlet specified, as applicable, for POL connection. **If the appliance is stored indoors, the cylinder must be disconnected and removed from the appliance. Cylinders must be stored outdoors in a well-ventilated area out of the reach of children.**

Note:

When an LPG unit is being directly connected to an LPG house system, you must follow the natural gas hook up guidelines. The installer must provide the proper gas regulator to reduce the gas flow to 2.75 kPa.

Note:

The Grill comes with the LPG Regulator/Hose assembly installed at the factory. The assembly, along with the entire Grill system, is leak tested. Do not remove the Regulator/Hose assembly from the Grill during installation.

! WARNING :

1. Do not remove the Grill from the pallet until you are ready to install.
2. Do not place the Grill directly on the ground or any other flat surface without support. This will prevent damaging the regulator/hose assembly by the weight of the grill.
3. Check the hose, regulator and connectors for damage. Look for cracks, abrasions, brittleness, holes, dents and nicks.
4. Do not attempt to remove, repair, or replace the Regulator/Hose assembly by yourself. It must be done by a qualified licensed gas fitter only.

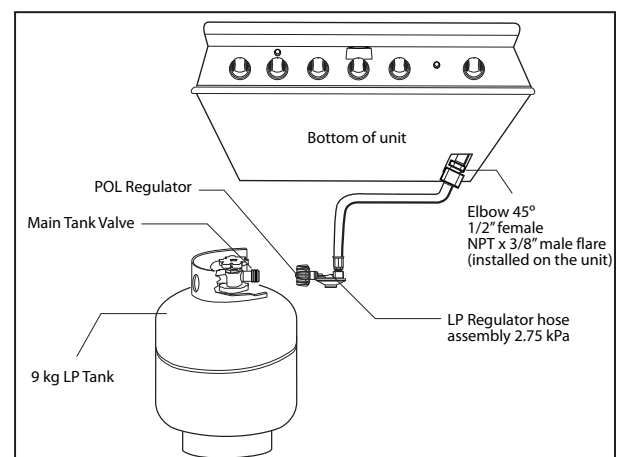

FIG. 12 LPG Gas

INSTALLATION

GAS HOOK-UP

LPG CYLINDER RESTRAINT FOR BUILT-IN INSTALLATION

If the grill is to be installed in a Built-in application, then the grill must be installed in accordance with the Built-in installation guidelines.

If you intend to operate your Built-in grill on LPG gas utilizing a minimum 9 kg cylinder, then the Built-in LPG cylinder restraint must be installed prior to initial use of the grill. If you do not have one please contact DCS by Fisher & Paykel for information on obtaining one. See section 'Service' for contact details.

The following steps will illustrate how to properly locate and install the LPG cylinder restraint within the Built-in enclosure.

NOTE:

The grill comes with the LPG Regulator/Hose assembly installed at the factory. The assembly, along with the entire grill system, is leak tested.

Do not remove the Regulator/Hose assembly from the grill during installation.

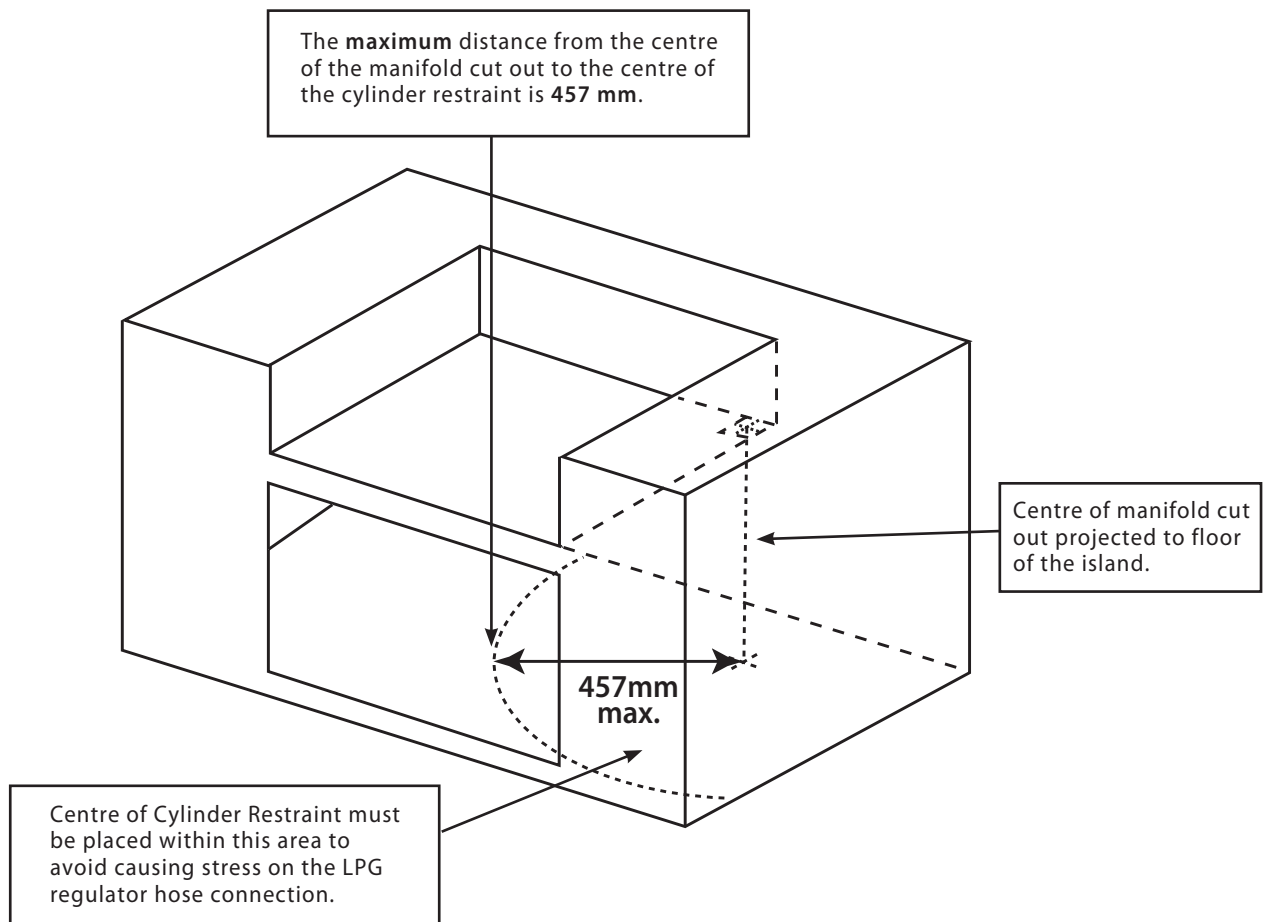

FIG. 13

INSTALLATION

GAS HOOK-UP

STEP 1

Place the cylinder restraint in the island (Fig. 14).

STEP 2

Locate the cylinder restraint in the island within the recommended area (Fig. 13 and 15).

STEP 3

Once located, secure to the bottom of the island using all eight hole locations provided on the restraint. Wood screws can be used for wooden floors or 1/4" (6mm) diameter anchor screws or bolts may be used if the floor is concrete or masonry (Fig. 16).

STEP 4

When secure, place the LPG cylinder into the cylinder restraint making sure to seat the cylinder all the way down, securely affixing the cylinder in the restraint (Fig. 17).

STEP 5

Attach the regulator hose assembly and operate the grill normally as described in the manual (Fig. 18).

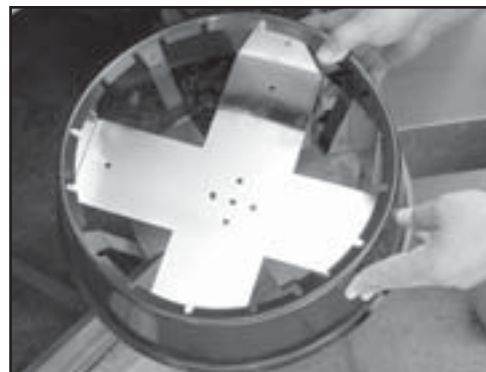

FIG. 14



FIG. 15



FIG. 16



FIG. 17

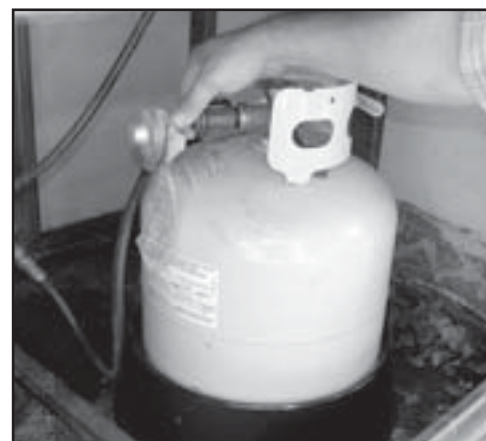

FIG. 18

INSTALLATION

LEAK TESTING -- PROCEDURE FOR A QUALIFIED GAS FITTER

Important!

There are two levels of testing for leaks. (1) Gas supply connection points that are accessible with the grill installed can be leak tested by the user. (2) Connections that are internal to the grill and therefore require disassembly should only be leak-tested by a licenced gas fitter. The full procedure below is to be performed by a licenced gas fitter only. Leak testing instructions for the user are in section 'Care and maintenance'.

GENERAL:

Although all gas connections on the grill are leak tested at the factory prior to shipment, a complete gas tightness check must be performed at the installation site by a qualified gas fitter due to possible mishandling in shipment, or excessive pressure unknowingly being applied to the unit. Check the whole system for leaks, or immediately check if the smell of gas is detected.

Before Testing:

Do not smoke while leak testing. Extinguish all open flames. Never leak test with an open flame. Make a soap solution of one part liquid detergent and one part water. You will need a spray bottle, brush, or rag to apply the solution to the fittings. For LPG units, check with a full cylinder. The valve panel must be removed to check the valves and fittings. Remove the knobs and the safety valve knob, then remove the 2 screws which fasten the valve panel to the unit (you will need a Philips screw driver for this). Pull the valve panel outward and unplug the wires from the ignition module and the back of the ignition button. In the back of the unit remove the screws which hold the service panel in place. Remove the service panel.

To Test:

Make sure all control valves are in the "OFF" position. Turn the gas supply "ON". Check all connections from the supply line, or LPG cylinder up to and including the manifold pipe assembly. Apply the soap solution around the connection, valve, tubing and end of the manifold. Soap bubbles will appear where a leak is present. If a leak is present, immediately turn off gas supply, tighten any leaking connections, turn gas on, and recheck. Check all the gas connections at the base of the control valves where they screw into the manifold pipe.

To check rotisserie burner and safety valve the burner must be lit, then leak test the connections located behind the service panel. If you cannot stop a gas leak turn off the gas supply and call your local gas utility, or the dealer you purchased the appliance from. Only those parts recommended by the manufacturer should be used on the grill. Substitution can void the warranty.

WARNING!

Do not use the grill until all connections have been checked and do not leak.

Check all gas supply fittings for leaks before each use. Keep a spray bottle of soapy water near the gas supply shut-off valve. Spray all the fittings. Bubbles indicate leaks (Fig. 19 & 20).

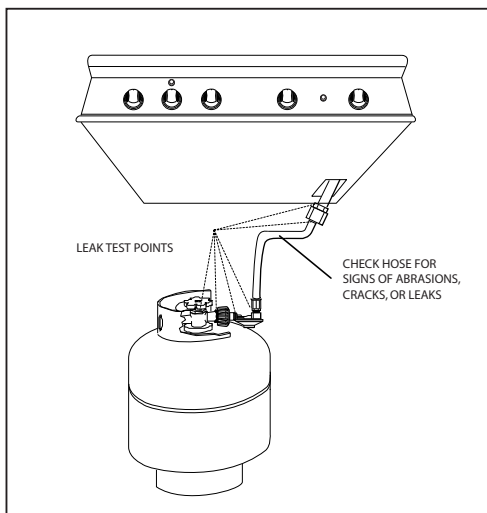

FIG. 19 LPG Gas

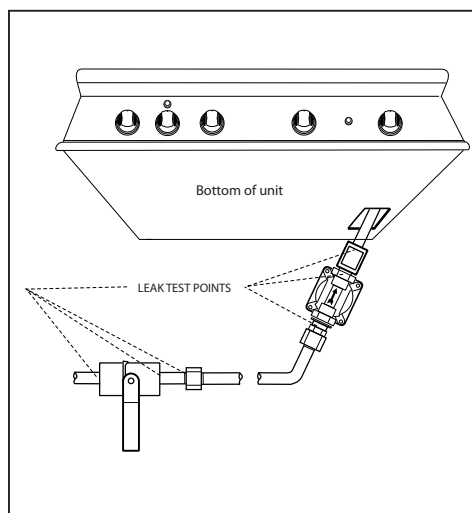

FIG. 20 Nat. Gas

INSTALLATION

BURNER ADJUSTMENT

Burner adjustment should only be performed by a licenced gas fitter.

GRILL BURNER AIR ADJUSTMENT:

Each grill burner is tested and adjusted at the factory prior to shipment; however, variations in the local gas supply or a conversion from one gas to another may make it necessary to adjust the burners. The flames of the burners (except the rotisserie burner) should be visually checked and compared to that of the drawing in Fig.21. Flames should be blue and stable with no yellow tips (LPG units may have some yellow tipping), excessive noise or lifting. If any of these conditions exist, check if the air shutter or burner ports are blocked by dirt, debris, spider webs, etc. Proceed with air shutter adjustment. The amount of air which enters a burner is governed by a metal cap at the inlet of the burner called an air shutter. It is locked in place by a screw which must be loosened prior to lighting the burner for adjustment.

GRILL BURNER FLAME HEIGHT:

Before beginning, ensure the grill is OFF and cool. To access the grill burner air shutters, first remove the grates, grease shields and radiants from the firebox, then remove the grill burner using instructions shown in section 'Care and maintenance'. With a screw driver, loosen the lock screw on the face of the air shutter slightly so that the air shutter can be adjusted.

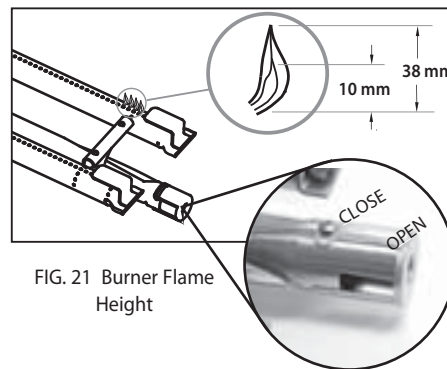

FIG. 21 Burner Flame Height

To Adjust:

1. Be careful as the burner may be very hot.
2. If the flame is yellow, indicating insufficient air, turn the air shutter counterclockwise to allow more air to the burner.
3. If the flame is noisy and tends to lift away from the burner, indicating too much air, turn the air shutter clockwise.

Reinstall the grill burner, ensuring the burner is level. Light the burner and check the flame. If all is okay, remove the burner (CAUTION - burner may be hot, allow time to cool) and tighten the air shutter screw. If not repeat the above procedure to readjust the air shutter.

LOW FLAME SETTING ADJUSTMENT:

The valves on the grill feature an adjustable low setting. Due to fluctuations in gas pressure, heating value or gas conversion, you may feel it necessary to increase or decrease gas flow in the low position. We do not recommend adjusting the infrared rotisserie burner.

To Adjust:

1. Light the burner.
2. Turn the control knob to the lowest setting (all the way counter-clockwise).
3. Remove the knob.
4. While holding the valve shaft with pliers, insert a thin, flat tipped screwdriver into the shaft and while viewing the burner adjust to a minimum stable flame (Fig. 22).

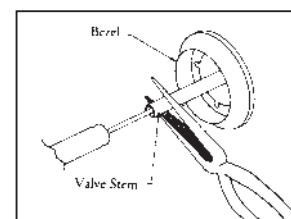

FIG. 22 Low Setting Adjustment

SIDE BURNER FLAME HEIGHT:

The correct height of the flame mainly depends on the size of the bottom of the cooking utensil, the material of the cooking utensil, the amount and type of food and the amount of liquid in the utensil. Following are some basic rules for selecting flame height.

- For safety reasons the flame must never extend beyond the bottom of the cooking utensil. Never allow flames to curl up the side of the pan (see Fig. 23).
- Utensils which conduct heat slowly (such as glass-ceramic) should be used with medium to low flames. If you are cooking with a large amount of liquid, a slightly larger flame can be used.

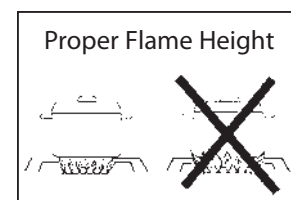

Fig. 23

WARNING: IMPORTANT!

If, after following the instructions above, the burners still cannot be adjusted to perform correctly, the appliance must not be used. Contact Customer Care. Before lighting, inspect the gas supply piping or hose prior to turning the gas "on". If there is evidence of cuts, wear, or abrasion, it must be replaced prior to use.

INSTALLATION

RADIANT ASSEMBLY

INSTALLING THE GREASE SHIELDS

The grease shields (2 per burner) help deflect any grease drippings away from the grill burner ports, preventing the ports from getting clogged. They come packed with the other accessories, in a separate bag.

Unpack the grease shields and position them on the pins above the grill burners (two per burner), as shown in Fig.24.

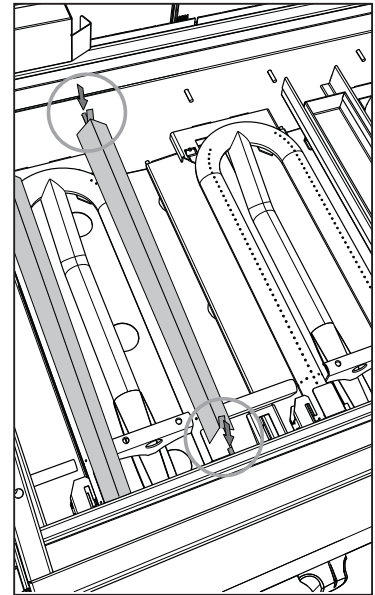

FIG. 24 Grease shields

RADIANT ASSEMBLY INSTALLATION:

1. Unpack ceramic rods and remove radiant (Fig. 25) from the unit.
2. Unlock radiant end cap by pushing it up with two fingers (Fig. 26).
3. Place 18 ceramic rods on the radiant (Fig. 27).
4. Lock radiant end cap (Fig. 28).
5. Place the assembled radiant in the unit (Fig. 29).



FIG. 25



FIG. 26



FIG. 27



FIG. 28



FIG. 29

Note:

In case a ceramic rod breaks:

- a) Unlock radiant end cap by pushing it up with two fingers (Fig. 26) or pliers may be used.
- b) Replace broken ceramic rod.
- c) Lock radiant end cap.

INSTALLATION

GRIDDLE PLATE

Note: the griddle plate is not supplied with the grill but may be purchased separately as an optional accessory . To purchase a griddle plate, contact Customer Care. See section 'Service' for contact details.

Griddle plate to be fitted to centre burner positions only

1. Remove grates from centre burner position.



2. Locate rear slots of griddle into grate support.



3. Sit front of griddle over grease channel.



Remove griddle plate only when completely cooled

1. Lift front edge of griddle plate.



2. Pull forward while lifting out



INSTALLATION

INSTALLER CHECKLIST

- Specified clearances maintained to combustibles.
- Verified proper enclosure ventilation.
- All internal packaging and any adhesive residue removed. To remove stubborn residue, use rubbing alcohol or a commercially available adhesive remover.
- Removed shipping brackets.
- Knobs turn freely, bezels centered.
- Each burner lights satisfactorily, individually or with adjacent burner lit.
- Air shutters adjusted.
- Low flame setting satisfactory.
- Drip pan in place properly and sliding freely.
- Heat Shields are located properly and in place.
- Pressure regulator connected and set for 1 kPa Natural, 2.75 kPa LPG gas.
- Manual shut-off valve installed and accessible.
- Unit tested and free of leaks.
- User informed of gas supply shut-off valve location.
- All radiants are assembled and put in place.
- Check match lighting.
- PLEASE LEAVE THESE INSTRUCTIONS WITH THE USER.
- USER, PLEASE RETAIN THESE INSTRUCTIONS FOR FUTURE REFERENCE.

INSTALLATION

INSTALLER CHECKLIST

NOTE:

If any of the listed items are missing, contact Customer Care. See section 'Service' for contact details.. Please be prepared with your Model #, Serial # and description of item(s) that are missing.

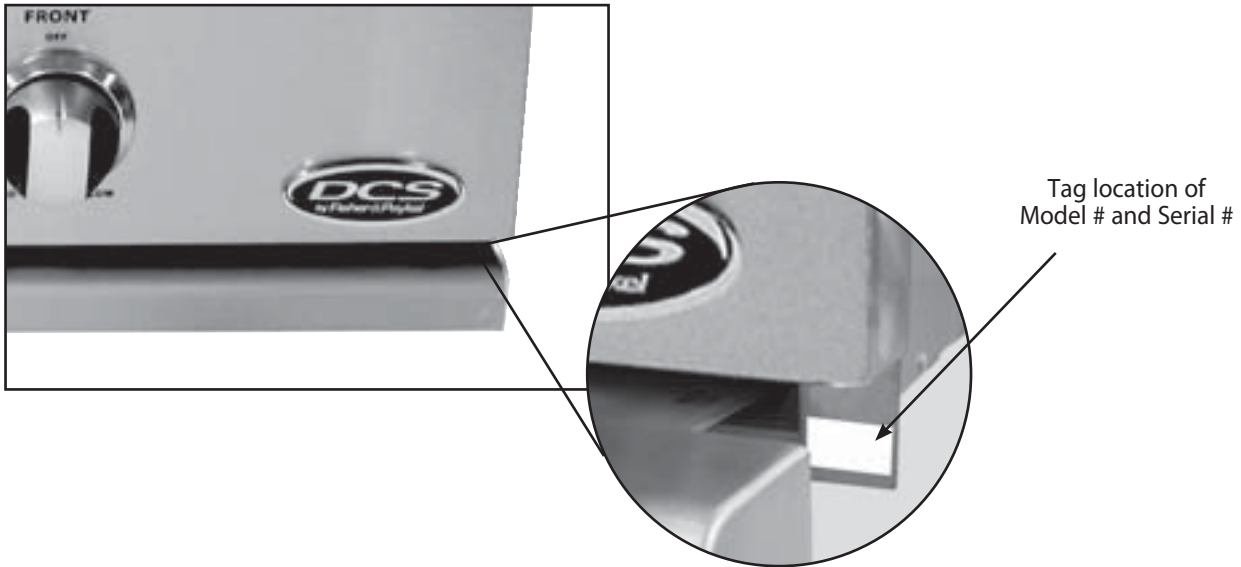

Read all installation instructions in this manual to see if the unit has been properly installed. If not done or done correctly, correct before using the unit.

USING THE GRILL

LIGHTING INSTRUCTIONS

BEFORE USING YOUR GRILL, CHECK THAT ALL PACKAGING HAS BEEN REMOVED.

TO LIGHT THE GRILL BURNER:

Open the grill hood and/or remove the top grate cover from side burner (for 48BQR) before lighting. Turn all knobs to "OFF". Turn the main gas supply on slowly. If you smell gas, shut off gas supply and call for service.

Push and hold the ignition button, turn the selected burner knob to "SEAR". If burner does not light in 4 to 5 seconds, turn knob "OFF" and wait 5 minutes before trying again to allow for any accumulated gas to dissipate.

Grill Match Lighting:

If the burner will not light after several attempts then the burner can be match lit. If you've just attempted to light the burner with the ignition, allow 5 minutes for any accumulated gas to dissipate. Keep your face as far away from the grill as possible and hold and pass a lighted match over the hole located on the top left for burner on the left, or the right hole for the right burner (Figs. 30, 31, and 32). Push and turn the control knob which is centred on the burner where the lit match is located, to "SEAR". If the burner does not light in 4 seconds, turn the knob off, wait 5 minutes and try again.



FIG. 30



FIG. 31

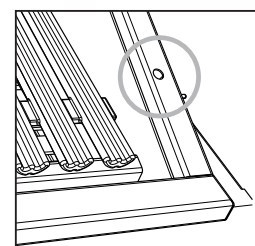

FIG. 32

Once the left or right burner is lit, the adjacent burner can be lit by the cross-lighting method. For centre burners to cross light, light the adjacent far left or right burner using the standard or match light procedure. Push and turn the control knob for the desired centre burner to "SEAR". The gas will be ignited by the adjacent burner's flame. If the burner does not light in 4 seconds, turn knob off, wait 5 minutes and try again.

NOTE:

In certain types of LPG cylinders, improper lighting procedures can cause the LPG cylinder flow control to activate, resulting in reduced heat output. If this is suspected, to reset flow control, shut off all burner controls and LPG cylinder valve, wait 30 seconds, then turn LPG cylinder valve on extremely slowly, wait five (5) seconds and push and hold the ignition button and turn burner valve on to "SEAR".

TO LIGHT SIDE BURNERS (48BQR MODELS ONLY):

CAUTION!

The side burner cover may be hot if the grill burners are in operation.

Side Burners Lighting Instructions:

First remove the burner cover and any cooking utensils from the burner grate. Push and hold the ignition button, turn the control knob to the "HI" position until the burner is lit or 4 seconds pass. If the burner doesn't ignite, wait 5 minutes for any accumulated gas to dissipate then try again. If the burner will not light after several attempts, section 'Troubleshooting'.

Side Burners Match Lighting:

Hold a lighted match near the burner ports, turn the control knob anticlockwise to "HI". Move your hand immediately once the burner is lit. Rotate the control knob to the desired setting.

Note:



If you are using propane gas, a slight pop or flash may occur at the burner ports a few seconds after the burner has been turned "off". This "extinction pop" is normal for propane gas.

Side burners:

The burner should never be operated if the cap is not in place (Fig. 34).

WARNING

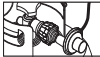
Failure to follow the steps in the order shown may cause the Flow Limiting Device to activate resulting in extremely low gas flow and improper operation.

-  All knobs must be in the OFF position before opening LPG cylinder valve.
-  Attach regulator hose assembly to cylinder.
-  Now open the LPG cylinder valve two (2) full turns minimum.

590475A 12/11

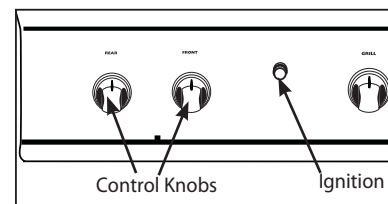

FIG. 33

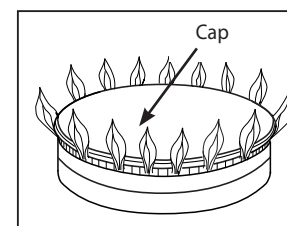

FIG. 34

USING THE GRILL

GRILLING

GRILL:

Each grill section consists of a large stainless steel burner, a series of ceramic rods encased in a stainless steel radiant, grease shield and a stainless steel heat retaining grate. Below the burners there is a stainless steel heat shield which reflects usable heat upward into the cooking area and reduces temperatures of the drip pan below. Above the burners are stainless steel radiants which encase the ceramic rods and protect the grill burner ports from blockage (Fig. 35).

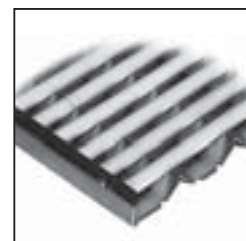

FIG. 35

The grill is supplied with radiant ceramic rods. Because of the porosity of ceramic rods, performance is superior in the rods' ability to capture heat as it rises from the grill burners. They also possess the thermal mass needed for even cooking performance. Flare ups are controlled because the radiant ceramic rods keeps grease from getting to the flames and igniting. The intense heat produced by this system produces true grilled flavour as fats and juices are brought to the surface of the food and caramelized. Discolouration of the grates is normal after use.

DIRECT/INDIRECT COOKING NOTES:

Direct cooking involves placing food on grates over lighted burners. Use this method for foods that take less than 20 minutes to cook or to sear larger items at the start of the cooking process that will then be indirectly cooked to finish. Place items on the preheated surface and leave until they no longer stick. Turning too soon and too often is one of the most common grilling mistakes. Never spray water on the grill or into grease. The patented Grease Management System™ reduces flare-ups by channeling grease away from the flame. Use a meat thermometer to achieve desired doneness and remove items one degree below how you would like to enjoy them, as the resting period before carving or consuming will raise the temperature.

Indirect cooking method is a popular alternative to direct heat grilling. Indirect cooking uses heat from adjacent burners to cook food and, in many cases, reduces the possibility of overcooked or overly browned food. Foods most appropriate for indirect grilling included breads thicker pieces of chicken or steaks. Indirect cooking involves placing the food on grates where the burners below are not lit and then closing the grill hood to create an oven effect. All the items you usually oven-roast can be grilled to perfection using indirect heating. Preheat the burners surrounding the food to be cooked. Use a roasting pan with a grid to hold food and add water or chicken broth to the pan to prevent the natural juices from burning or evaporating.

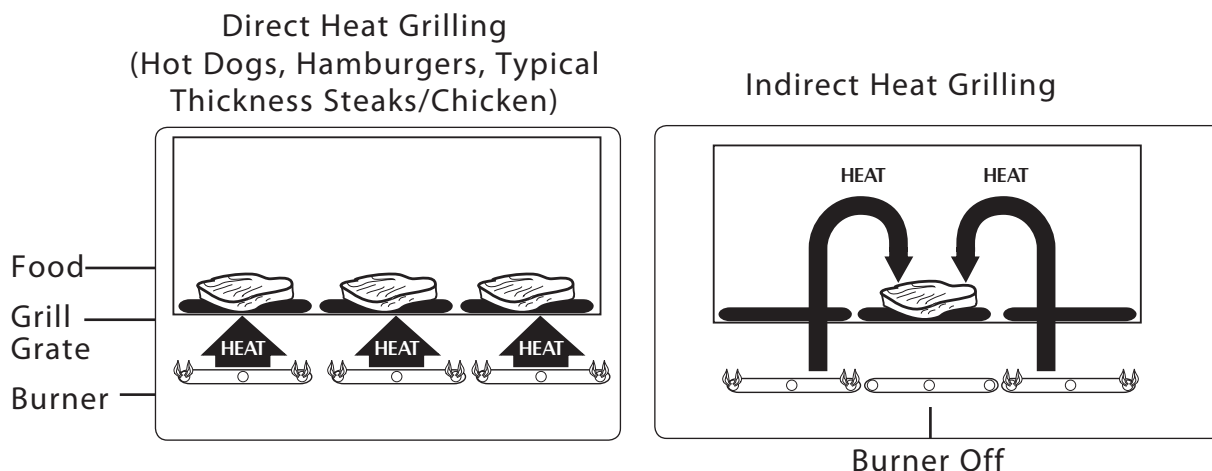

IMPORTANT Using the Grill:

To season the grates, pour a tablespoon of vegetable oil on a soft cloth and rub on both sides of the grates. Only a light coating is needed and some smoke may be visible during the preheating. Grilling requires high heat for searing and proper browning. When grilling large pieces of meat or poultry, it may be necessary to turn the heat to a lower setting after the initial browning. This cooks the food through without burning the outside. Foods cooked for a long time or basted with a sugary marinade may need a lower heat setting near the end of the cooking time.

USING THE GRILL

GRILLING (Continued)

1. Check to be certain the drip pan and grease tray are in place.
2. Light the grill burners using the instructions in section 'Lighting instructions'.
3. Once you have verified the burners are lit, preheat the grill for 5 to 10 minutes.
4. Place the food on the grill and cook to the desired doneness. Adjust heat setting, if necessary. The control knob may be set to any position between "SEAR" and "LOW" - most grilling is done between "MED" and "LOW" settings.
5. When you have finished using the grill, turn the burner knobs to "OFF" and shut off the main gas supply.
6. Allow grill to cool and clean the grates, drip pan and grease tray after each use.

CAUTION!

Never cook food with all grill burners on "SEAR" with the grill hood open for more than 30 minutes.

Note:

If using LPG gas, your preheat time may be shorter than recommended. To prevent overcooking or burning, you may want to lower heat settings.

GRILLING HINTS:



The doneness of meat, whether rare, medium, or well done, is affected to a large degree by the thickness of the cut. Expert chefs say it is impossible to have a rare doneness with a thin cut of meat. The cooking time is affected by the kind of meat, the size and shape of the cut, the temperature of the meat when cooking begins, and the degree of doneness desired. When defrosting meats it is recommended that it be done overnight in the refrigerator as opposed to a microwave. This in general yields a juicier cut of meat. Use a spatula instead of tongs or a fork to turn the meat, as a spatula will not puncture the meat and let the juices run out. To get the juiciest meats, add seasoning or salt after the cooking is finished and turn the meat only once (juices are lost when the meat is turned several times). Turn the meat just after the juices begin to bubble to the surface. Trim any excess fat from the meat before cooking. To prevent steaks or chops from curling during cooking, slit the fat around the edges at 5 cm intervals.

DUAL-SIDED GRATES:

Whether you or your guests crave seafood, steak or veggies, the double-sided grates provide varying surfaces for varying textures. The "W"-shaped side creates nice sear lines for steaks, chicken and chops and routes oil and grease away from the food. The opposite "radius" side offers more surface area for support and handling of delicate items like scallops. (See below for a sample list of which foods to cook on which side of the grate.) Keep the grates mixed—half on one side and half on the other or a percentage that best represents what you are cooking.

USING THE GRILL

GRILLING

"W"-SHAPED GRATE 	RADIUS GRATE 
<ul style="list-style-type: none"> • chicken (bone-in and boneless cuts) • steaks • chops • burgers • ribs • kabobs • steak cuts of fish like tuna and swordfish • whole fish • game • oysters • large slices of whole vegetables and mushrooms • fruit • bread • sausages • hot dogs 	<ul style="list-style-type: none"> • delicate fish fillets • lobster meat • shrimp • scallops • clams • mussels • suckling pig • turkey legs • indirect cooking and smoking • potatoes • smaller vegetables or slices • roasted peppers • roasted whole garlic • pizza dough and flat breads • crab cakes

USING THE ROTISSERIE

The grill rotisserie system is designed to cook items from the back using infrared heat. The location of the burner allows the placement of the rotisserie basting pan (included) beneath the food to collect juices and drippings for basting and gravy. To flavour the contents of the basting pan, you can add herbs, onion, garlic, or spices. Hams are especially good with the addition of pineapple slices and brown sugar to the basting pan. The rotisserie burner is an infrared type which provides intense searing radiant heat. Preferred by chefs over other methods, this intense heat is magnificent for searing in the natural juices and nutrients found in quality cuts of meat.

Once lit, the rotisserie burner will reach cooking temperatures in about 1 minute. The orange/red glow will even out in about 5 minutes. The rotisserie motor is equipped with metal gears and is capable of turning up to a 25 kg cut of meat or poultry. The rotisserie motor on the grills is secured down to a cast rotisserie block with two black screw-down knobs. The rotisserie block is in turn bolted to the side panel. The rod for the rotisserie is assembled into the motor assembly by placing the pointed end into the motor, and resting the handle end on the support at the left side of the grill. With the rod pushed as far as possible into the motor, the grooved rod should rest on the rollers.

To load the rod begin with the handle in place, and slide one of the meat holders (prongs facing away from the handle) onto the rod. Push the rod through the centre of the food, then slide the second meat holder (prongs toward the food) onto the rod. Centre the product to be cooked on the rod then push the meat holders firmly together. Tighten the 'L'-shape screw with pliers. It may also be necessary to wrap the food with butchers string or dental floss (never use nylon or plastic string) to secure any loose portions. Once the food is secure, insert the rod into the motor. If needed, remove the grill grates. Place the basting pan beneath the food. It is normal for the rod to flex when larger cuts of meat are being cooked.

Also, the motor is equipped with a halogen bulb to provide light when other sources of light are not sufficient. Use only a 40W Max. Halogen Narrow Flood replacement bulb.

WARNING!

Halogen lamps are constructed of a glass bulb with a pressurized internal filament tube that operates at high temperatures and could unexpectedly shatter. Should the outer bulb break, particles of extremely hot glass could be discharged into the fixture enclosure and/or surrounding environment, thereby creating a risk of personal injury or fire. When replacing the bulb, let the bulb cool, and assure that power to the light has been turned off. Never allow the hot bulb to come into contact with water. **DO NOT TOUCH** the light bulb when in use. It may be hot enough to cause injury.

Do not immerse the rotisserie unit in water.

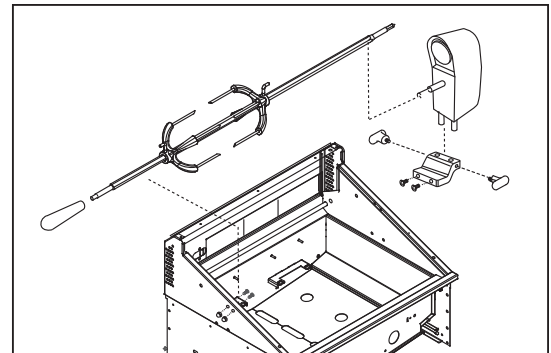

FIG. 36

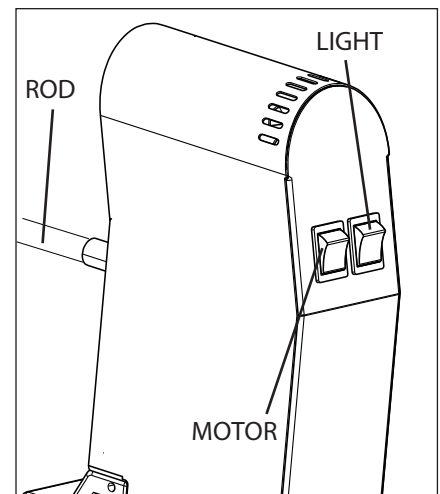

FIG. 37

USING THE ROTISSERIE

WARNING!

Never have the grill burners (bottom burners) on during Rotisserie cooking. It will burn your meat and make it very dry. Use only one section at a time, grill or rotisserie.

Do not cover or obstruct the upper or lower vents on the rotisserie motor unit. The motor is air-cooled and blocking these vents may cause the motor to overheat shortening its lifespan.

PREPARATION

Recommended:

Dental floss or butcher string, scissors, broiler pan (bottom only), pliers, instant read thermometer, foil, and oven mitts.

Working Area:

Allow enough space to accommodate food and rotisserie rod assembly in a clean environment.

Meat Preparation:

Tie meat with butcher string or Dental floss in three areas. Buy a roast that is equally balanced from top to bottom in size. The meat will cook more evenly while on the Rotisserie. For Poultry, tie wings and legs to the body using Dental floss or butcher string to prevent flopping around while turning. (Fig. 38)



FIG. 38

1. Determine the centre placement for the food, put first prong on the rod, turn 'L'- shaped screw to tighten.
2. Centre tied meat/poultry on the rod, place second prong, turn 'L'- shape screw to tighten. (Fig. 39)
3. Pick up the rod, rotate it to check for balance. If not, adjust prongs and food to balance. Take pliers and tighten the 'L'- shape screws on both sides of the prong.
4. Remove grates and top rack on the grill. Place bottom portion of broiler pan on ceramic rods, so meat drippings can be caught in pan. (Fig. 40).



FIG. 39



FIG. 40

USING THE ROTISSERIE

TO LIGHT THE ROTISSERIE BURNER BEFORE COOKING:

The location of the rotisserie burner makes it more susceptible to strong wind conditions, more so than the protected grill burners. For this reason you should avoid operating the rotisserie during windy conditions. As an added safety feature we've equipped the burner with an automatic safety valve which will not allow gas to flow to the rotisserie burner unless the following conditions are present with the knob on:

1. The safety valve button is pressed, and held down.
2. The safety valve thermocouple has been sufficiently heated to keep safety valve open.

Open the hood. Push and hold the ignition button. You'll hear a snapping sound. Turn the control knob to "HI". Engage the safety valve button and continue to hold until the burner is lit. Once lit, turn control knob to desired setting. If the burner does not light within 4 to 5 seconds, release the safety valve button and turn the control knob to "OFF" and wait 5 minutes before trying again.

- *If relighting a hot burner, wait 5 minutes.*
- *Never leave the control knob on if rotisserie is not in use.*
- *Never light a grill burner under the rotisserie while rotisserie burner is lit.*

MANUAL LIGHTING:

To manually light the rotisserie, place a butane lighter near the tip of the thermocouple as shown in Fig. 41. Turn the control knob to "HI". Hold the safety valve button in for about 4 to 5 seconds or until the burner remains lit. Once lit, turn control knob to desired setting. If the burner does not light within 4 or 5 seconds, release the safety valve button and turn the control knob to "OFF" and wait 5 minutes before trying again.



FIG. 41

WARNING!

Keep hands and face away from front of burner! STAND TO THE SIDE WHEN LIGHTING. ONCE LIT MOVE HAND AWAY QUICKLY.

WARNING!

Electrical Grounding Instructions: This appliance (rotisserie motor) is equipped with a three-prong (grounding) plug for your protection against shock hazard and should be plugged directly into a properly grounded three-prong receptacle or a three-prong grounded extension cord rated for the power of the rotisserie motor and approved for outdoor use. Do not cut or remove the grounding prong from this plug. Use only a residual current device (RCD) protected circuit.

The rotisserie motor must be electrically grounded in accordance with local codes. The rotisserie motor should be supplied through a residual current device (RCD) having a rated residual operating current not exceeding 30 mA. Keep the rotisserie motor electric cord away from the heated surfaces of the grill. When not in use, remove and store the motor in a dry location. To protect against electric shock, do not immerse the cord or plug in water or other liquid. Unplug rotisserie unit from the outlet when not in use and before cleaning. Allow the rotisserie to cool before putting on or taking off parts.

USING THE ROTISSERIE

COOKING ON ROTISSERIE

1. Place prepared rod into motor, lay across to other side in groove (Fig.42).
2. Verify placement as shown in Fig. 43.
3. Ignite burner, start rotisserie motor, and keep on rotisserie valve on "high" for cooking all meats on the rotisserie.
4. To check temperature of the meat, turn off motor, turn temperature to low while using your instant-read thermometer. For poultry it should read 75°C in the breast. Thermometer should touch the breastbone, then lift up 2 cm from the bone to get a more accurate temperature reading. Remove thermometer and turn on motor, return heat to high if more cooking is needed. Repeat above instructions (Fig. 44).
5. When you have finished using the rotisserie, turn off motor and turn the rotisserie knob to "OFF". If you have finished using the appliance altogether, turn the main gas supply off too.
6. Remove the rod, using oven mitts, place meat or poultry on broiler pan, then remove prongs (Fig. 45).



WARNING!

The fork rods are very sharp. Keep hands away from tips when removing the food.

7. Cover with foil for a 15 to 20 minute waiting time. Meat will carve better and juices will go back into the meat.

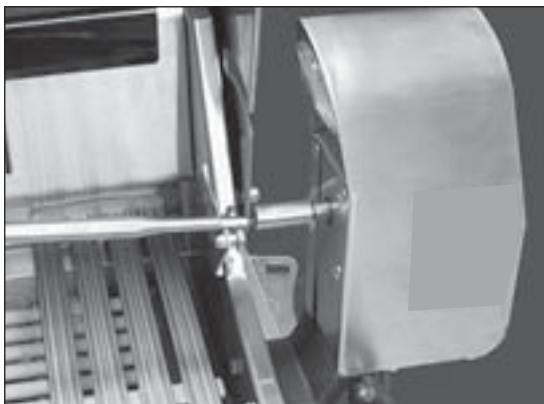

FIG. 42



FIG. 43

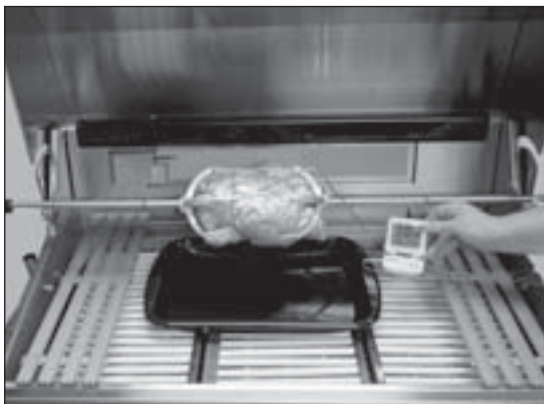

FIG. 44



FIG. 45

CARE AND MAINTENANCE

GENERAL ADVICE

- Before carrying out any cleaning or maintenance, make sure that all burners are off, and gas to the appliance has been shut off at the cylinder valve or shut-off valve.
- Beware of hot surfaces. If you clean surfaces while they are still warm, make sure to wear barbecue mitts for protection against heat and steam.
- Clean and inspect the grill regularly, following the maintenance schedule below.
- Keep the grill covered when not in use.

RECOMMENDED MAINTENANCE SCHEDULE

Before each use...

- inspect the gas supply hose or piping for cracks, kinks, and any sign of abrasion or wear. If you find evidence of any of these or are in doubt, do not use the appliance until it has been checked by a qualified gas fitter.

After each use...

- clean the grease tray to prevent grease accumulating, as grease deposits can become a fire hazard.

At the start of each season, or if the grill hasn't been used for several weeks...

- check supply connections for gas leaks. See following page for instructions. If there is any evidence of leaks, do not use the appliance until it has been checked by a qualified gas fitter.
- inspect the grill burners thoroughly for spider webs and insect nests. If not removed, these could cause a hazardous situation by blocking gas flow to the burners. Gas could then accumulate in the front of the grill and catch on fire (called a 'flashback' fire). See further below for instructions on removing the grill burners for cleaning.
- check the grill burners for clogged burner ports and any other sign of debris and blockage, clear if necessary.

Periodically...

- clean and re-season the grill grates and griddle plate.
- clean the full-width drip pan to prevent grease accumulating, as grease deposits could become a fire hazard.
- check the power supply cord of the rotisserie motor for signs of damage. The rotisserie is not be used if its cord is damaged.

At least twice a year...

- have a qualified gas fitter check the gas supply connections and the entire system for gas leaks and signs of damage or wear and tear.
- have a qualified gas fitter check the injectors for any sign of blockage or insect activity.

At least once a year...

- check the spark ignition, and if necessary, replace the battery.

Every five years...

- Replace the hose on the 'Quick-connect' device (if used).

CARE AND MAINTENANCE

LEAK TESTING – PROCEDURE FOR THE USER

IMPORTANT!

There are two levels of testing for leaks. (1) Gas supply connection points that are accessible with the grill installed can be leak tested by the user. (2) Connections that are internal to the grill and therefore require disassembly should only be leak tested by a qualified gas fitter. The procedure below does not require any special expertise and can be performed by a user. If you do not feel comfortable performing the leak test, seek the help of a qualified gas fitter.

When to check for leaks

- At the start of each season, or if the grill hasn't been used for several weeks.
- Every time the LPG cylinder is replaced (if applicable).

Before leak testing

- Make sure that all the burners are OFF.
- Do not smoke while leak testing.
- Extinguish all open flames. Never leak test with an open flame.
- Make a soap solution one part liquid detergent and one part water. You will need a spray bottle, brush, or rag to apply the solution to the accessible gas supply connection points. For LPG units, check with a full cylinder.
- Note: we recommend keeping a spray bottle of soapy water handy near the grill for your convenience.

To test

1. Make sure all knobs are in the OFF position.
2. Turn the gas supply ON.
3. Check all the leak test points shown in the applicable drawing below (LPG or Natural gas supply) by applying the soap solution around each connection.

If there are no soap bubbles...

The connections are leak free. You can use the grill.

If soap bubbles appear...

Bubbles indicate a leak. If a leak is present, immediately turn off gas supply at the cylinder valve or shut-off valve, and arrange for a qualified gas fitter to inspect and tighten the gas connections. Do not use the grill until all connections have been checked, tightened if necessary, and verified to be leak free by a qualified gas fitter.

IMPORTANT!

- Do not use the grill until all connections have been checked and do not leak.

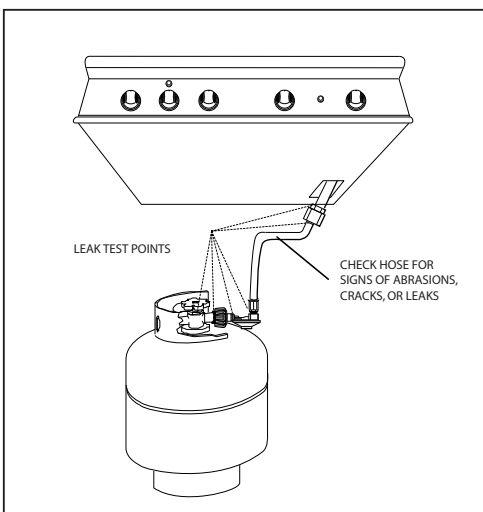

FIG. 46 LPG Gas

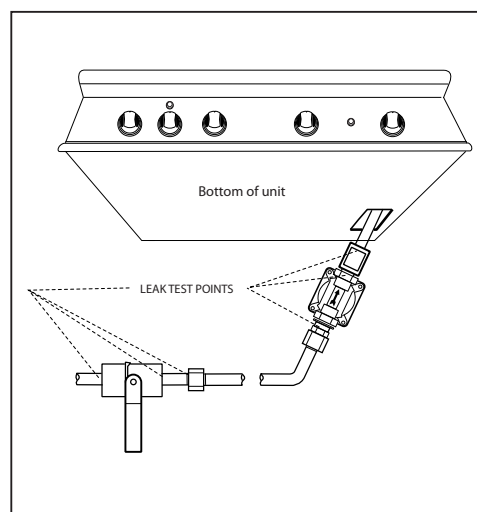

FIG. 47 Nat. Gas

CARE AND MAINTENANCE

BATTERY REPLACEMENT:

1. Carefully remove the drip pan, following the instructions under section 'Drip pan' further below.
2. Open cart door (on cart model only).
3. Pull battery downwards (This may require use of pliers).
4. Re-install upward and push to snap - Fig. 48. (Polarity is shown in Fig. 49).



FIG. 48

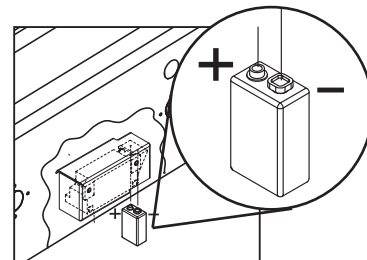

FIG. 49

Note:

Battery condition should be checked at least once a year.

REGULATOR AND HOSE REPLACEMENT

The pressure regulator and hose assembly supplied with the unit must be used. If replacements are needed, contact Customer Care. See section 'Service' for contact details. Do not use the grill if the odour of gas is present. If the unit is LPG, screw the regulator into the cylinder and leak check the hose and regulator connections with a soap and water solution before operating the grill. Turn all knobs to "OFF" then turn on the gas supply. If LPG, is there gas in the cylinder?

- Always keep your face and body as far away from the grill as possible when lighting.
- DO NOT leave the grill unattended while cooking.
- Keep a spray bottle of soapy water near the gas supply valve and check the connections before each use.
- Do not attempt to light the grill if the odour of gas is present.
- Wait 5 minutes before relighting a hot grill.

WARNING: IMPORTANT!

Before each use, inspect the gas supply piping or hose prior to turning the gas "on". If there is evidence of cuts, wear, or abrasion, it must be replaced prior to use.

GRILL GRATES:

Method 1: Turn on "HI" for 15-20 minutes to burn any remaining food particles. After turning the grill "OFF", use a bristle barbecue brush to remove any remaining food particles or ash.

Method 2: The easiest way to clean the grill is immediately after cooking is completed and after turning off the flame. Wear a barbecue mitt to protect your hand from the heat and steam. Dip a soft brass bristle barbecue brush in a mixture of 2 cups of tap water and 1/2 cup of vinegar and scrub the hot grill. Dip the brush frequently in the bowl of water and vinegar. Steam, created as water contacts the hot grill, assists the cleaning process by softening any food particles. The food particles will fall onto the ceramic rods and burn or fall into the drip pan. If the grill is allowed to cool before cleaning, cleaning will be more difficult.

Method 3: Take about 30 cm of aluminum foil, crumpled up in a ball and rub it over cooled grates to release food particles.

Note:

Grill grates must be re-seasoned after cleaning to prevent rust stains.

CARE AND MAINTENANCE

CERAMIC RODS:

It is not necessary to remove the ceramic rods for cleaning. They burn themselves clean during the next cooking operation. Periodically the trays holding the ceramic rods need to be turned over, and shaken free of debris for a thorough cleaning. How often you use the grill and the amount and type of food cooked will determine when it is necessary to clean the trays. If grease can be seen on the top of the tubes or if you get a lot of flare-up during cooking, the tubes need to be turned over and heated on "HI" for 30 minutes; longer for heavy soil.

HEAT SHIELDS:

These are located underneath the grill burners in the middle. Their purpose is to reflect heat back up towards the grates, preventing the drip pan from getting too hot. They should not need cleaning. If they need removed or put back in place (ie if they have moved in transit), please follow the following instructions:

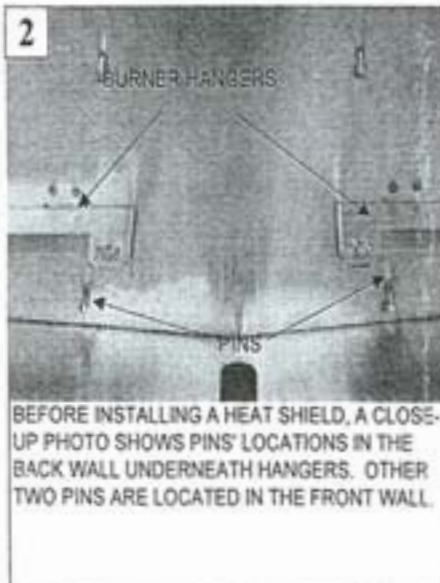
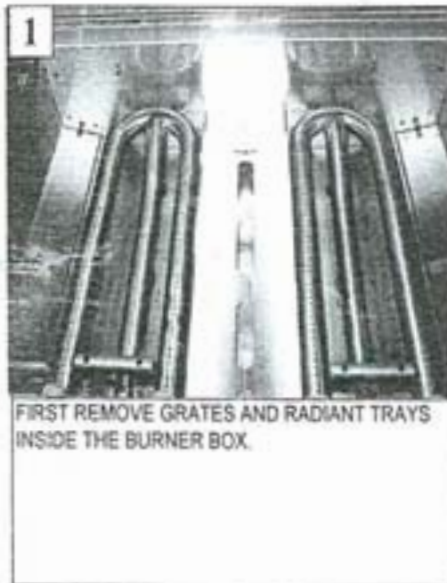
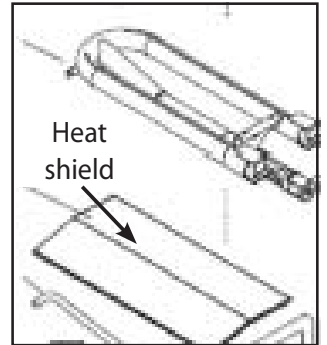

CARE AND MAINTENANCE

GREASE TRAY

- Most of the grease from grilling, as well as boilovers and spills from the side burners (48BQR models only) are channelled into the small grease tray insert.
- Clean the grease tray after every use, but only after its contents have had time to cool. If not cleaned, accumulated grease may catch on fire.
- To clean, use hot water and dishwashing liquid. If necessary, soak the grease tray in hot soapy water to soften stubborn residue. You may also use a non-abrasive nylon scourer.

DRIP PAN

- The full-width drip pan collects any additional splatters and drippings not channelled into the grease tray.
- Check and clean the drip pan periodically to prevent the accumulation of grease.
- To clean, wipe out with a hot soapy cloth. Use a spatula to scrape off any dried-on residue.

To remove and replace the drip pan and grease tray for cleaning

1. Make sure that all the burners are off, the gas supply has been shut off at the cylinder or shut-off valve, and that the grill and the contents of the drip pan and grease tray have had time to cool.
2. Slowly begin pulling the drip pan out by its handle, taking care not to spill any grease on the ground or yourself.
3. Once the grease tray insert is fully visible, unhook its tab in the front and remove.
4. If you need to clean the drip pan too, first ensure you will have a large enough and level surface, such as a bench-top, for placing it on. You may also want another person to help, as the drip pan is wide and difficult to balance by one person. Continue pulling the drip pan all the way out, then grab it on either side (being careful of sharp edges) and remove from its slot. Place on a level surface.
5. To replace, follow these steps in reverse order. Make sure that the grease tray locates securely in place and the drip pan is pushed all the way back. Take care not to catch your fingers under the handle when pushing the drip pan in.

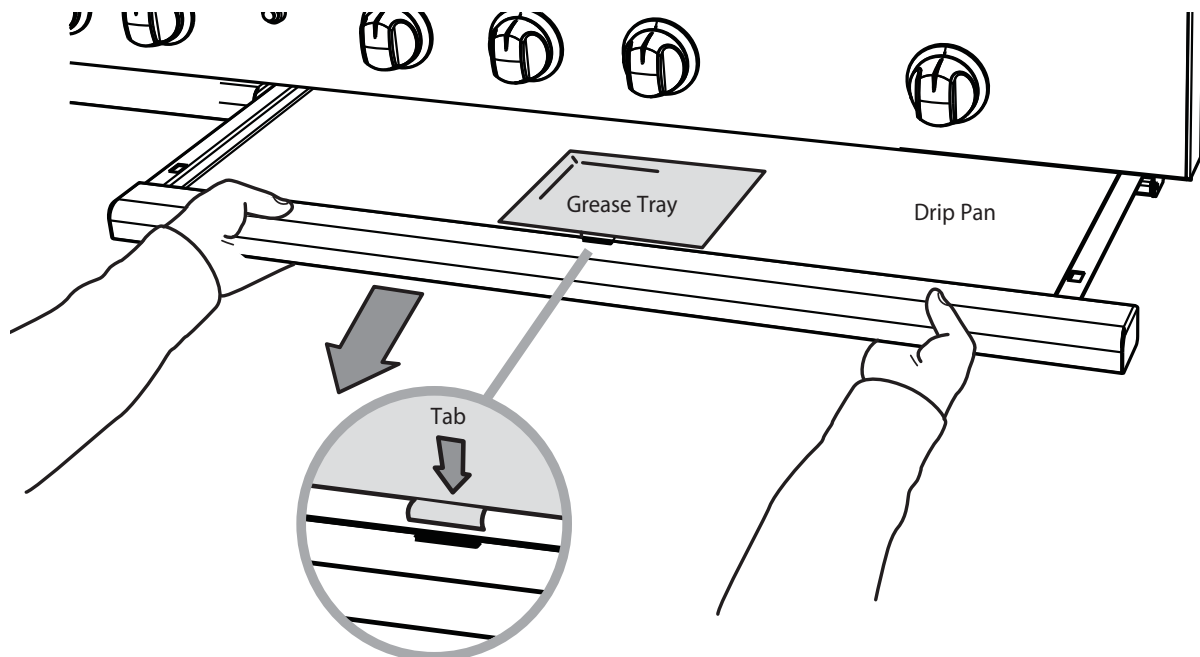

CARE AND MAINTENANCE

DROP-ON GRIDDLE PLATE (NOT SUPPLIED WITH UNIT, PURCHASED SEPARATELY)

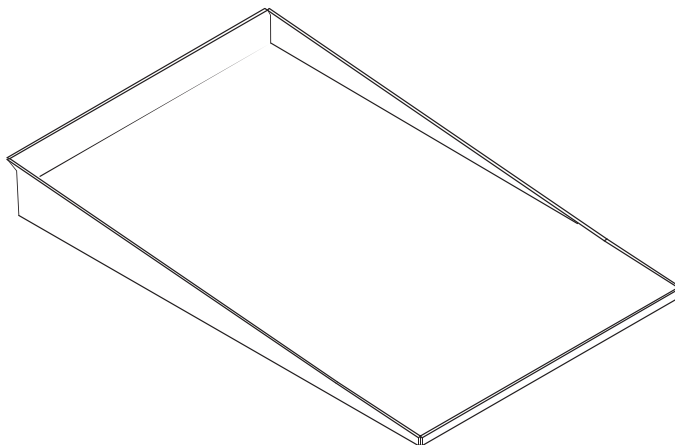

BEFORE USING THE GRIDDLE FOR THE FIRST TIME OR TO RE-SEASON

1. Clean the griddle thoroughly with hot soapy water to remove any protective coating.
2. Rinse with a mixture of 4 cups water and 1/4 cup white vinegar. Dry thoroughly.
3. Pour 1 teaspoon vegetable oil into the centre of the griddle (do not use corn oil as it gets sticky). Rub the oil over the entire surface of the griddle using a heavy cloth.
4. Place the griddle on the centre grill rack, light the burner and turn the control knob to a medium setting.
Turn the heat off when the oil begins to smoke. Allow the griddle to cool.
5. Repeat Step 3. Be sure to cover the entire surface with the oil.
6. Repeat Step 4. Allow the griddle to cool. Wipe the entire surface of griddle using a heavy cloth. Apply a very thin layer of vegetable oil. The griddle is now ready to use.

If the griddle is not used for a period of time, re-season it to avoid rusting.

CARE AND MAINTENANCE

STAINLESS STEEL:

The grill is made from non-rusting and non-magnetic stainless steel. After initial usage, areas of the grill may discolour from the intense heat given off by the burners, this is normal. There are many different stainless steel cleaners available. Always use the mildest cleaning procedure first, scrubbing in the direction of the grain. To touch up noticeable scratches in the stainless steel, sand very lightly with wet 100 grit emery paper in the direction of the grain. Specks of grease can gather on the surfaces of the stainless steel and bake on to the surface and give the appearance of rust. For removal use an a mildly abrasive pad in conjunction with a stainless steel cleaner. Always rub in the direction of the grain.

Note:

Stainless steel tends to corrode in presence of chlorides and sulfides especially in coastal areas. To ensure corrosion prevention, wash all stainless steel surfaces every 3-4 weeks with fresh water and stainless cleaner. Keep grill covered when not in use.

SIDE BURNER IGNITORS:

Wipe with a water dampened cotton swab. Be careful not to damage the ignitor (see Fig. 50).

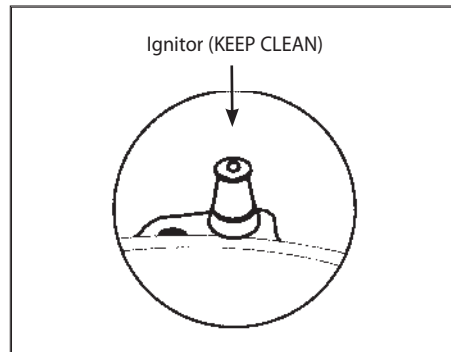

FIG. 50

TO REMOVE THE GRILL BURNERS FOR CLEANING

1. Ensure the burners have cooled and the gas supply has been turned off at the cylinder valve or shut-off valve.
2. Remove the grill grates, then lift out the radiant trays and grease shields (Fig. 51).
3. Using a Phillips screwdriver, unscrew the clamps holding the burners in place on either side Fig. 52. Put the clamps and screws safely aside.
4. Grasp the curved section of the burner in the rear and gently pull up to release the securing tabs from the rear support bracket.
5. Move the burner slightly away from you so as to slide it out from the collector box and disengage the burner inlet from the injector inside the valve hole in the front (Fig. 54).
6. Angle the burner sideways and lift out.

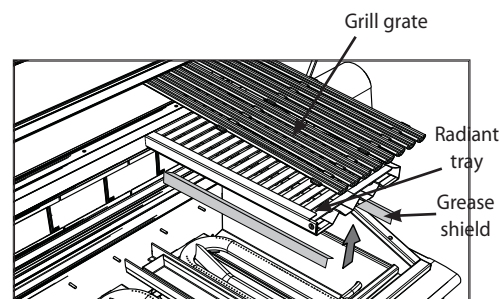

FIG. 51

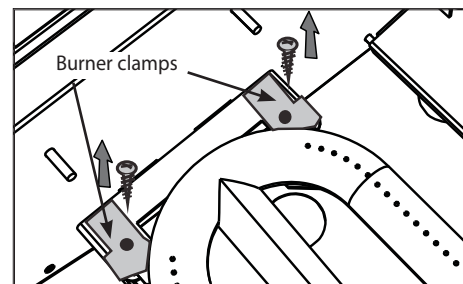

FIG. 52

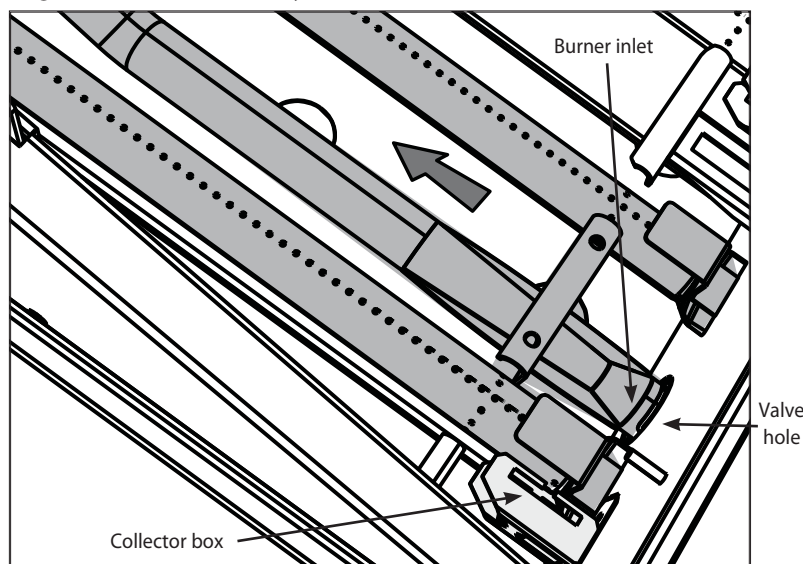

FIG. 54



FIG. 53

CARE AND MAINTENANCE

GRILL BURNER CLEANING:

Clean the exterior of the burner with a stainless steel wire brush. Clear stubborn scale with a metal scraper. Clear any clogged ports with a straightened paper clip. Never use a wooden toothpick as it may break off and clog the port. Shake out any debris through the air shutter opening (Fig. 55). Use a flashlight to inspect the burner inlet to ensure it is not blocked. If obstructions can be seen, use a metal wire coat hanger that has been straightened (See Fig. 56).

INJECTOR CLEANING:

Injectors should be checked for signs of blockage twice every year. As injector removal requires a special tool, this must be done by a qualified gas fitter only. Removal of injectors by an unqualified person may create a hazardous situation.

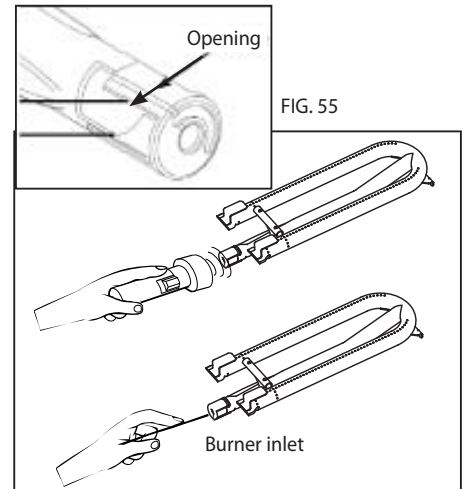

FIG. 56

TO REPLACE THE GRILL BURNERS AFTER CLEANING

1. With the burner held at a 45 degree angle front to back, lower each grill burner back into place, ensuring that the burner inlet is centred on the injector inside the valve hole in the front (Fig. 57), and that the burner slides into the collector box on the side, as shown in Fig. 58.

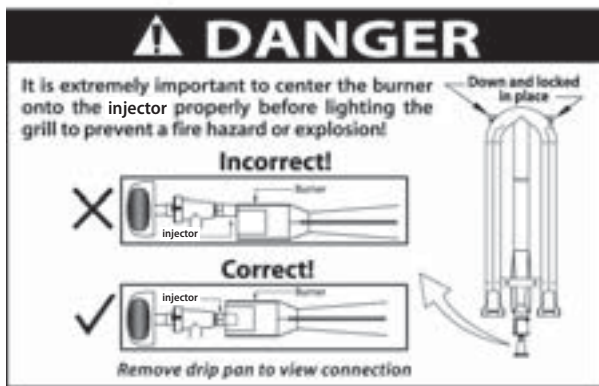
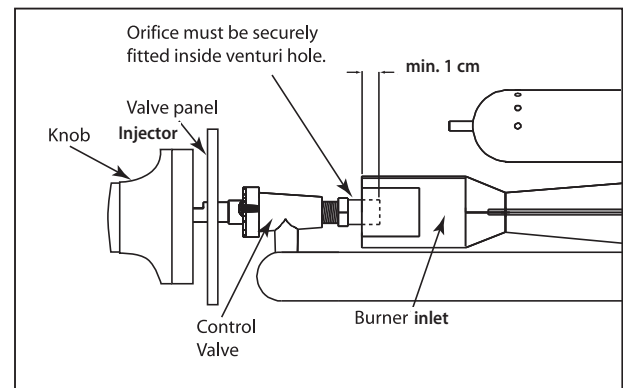
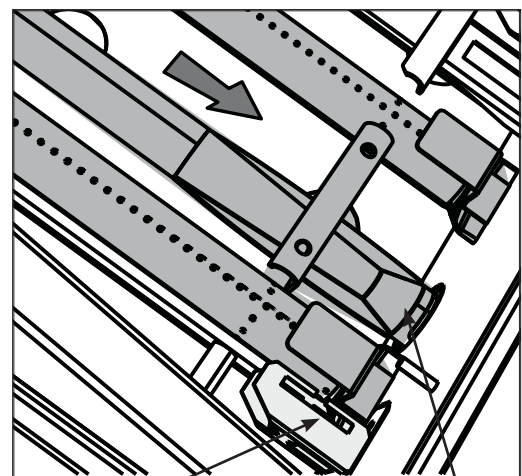

Fig. 57



2. With the burner inlet and side properly in place, locate the tabs at the rear of the burner into the matching slots on the support bracket. Check that the burner is level and does not rock.
3. Refit the clamps and fixing screws to secure the burner in place.
4. Light all the burners and check for proper flame characteristics. If adjustments are necessary, refer to the 'Burner adjustment' page in the 'Installation' section.
5. Once you have verified that the burners function correctly, replace the grease shields, radiant trays, and grill grates.



Collector box

Fig. 58

Burner inlet

CARE AND MAINTENANCE

SIDE BURNER GRATES (BGB48 BQR MODEL):

When lifting the grates be careful as they are heavy. Place them on a protected surface, so they won't scratch the surface they are laid on. The burner grates are matte enamel over cast iron. When cool, they may be wiped clean using hot soapy water, then rinsed and wiped dry. The burner grates will not rust as they are matte enamel on both sides for durability.

The enamel may pop off the edge of the grates due to rapid temperature change when the burners are turned on. Do not be concerned as this does not result in the deterioration of the grates. The cast iron soon darkens to blend with the enamel. Be careful when wiping an area where the enamel has popped off, as the edges may be sharp.

SIDE BURNERS (BGB48 BQR MODEL):

For proper lighting and performance keep the burners clean. It is necessary to clean the burners if they do not light even though the ignitor clicks, if there has been a severe boil over, or when the flame does not burn blue. Be certain all burner knobs are in the off position before attempting to clean the burners. The burners have been designed for ease in cleaning. When the grates and burners are cool, remove the grate. The burner cap and the brass port ring can easily be lifted off. Wash these parts in hot soapy water, rinse and dry thoroughly. The burner caps are porcelain enamel. Follow the directions that were given for the burner grates. A bristle brush can be used to clean out the toothed burner ports, if necessary. After cleaning, it is important to make sure the location pins on the bottom side of the port ring are properly aligned with the corresponding holes in the base. Incorrect alignment will produce a potentially dangerous flame and poor burner performance (see Fig. 59).

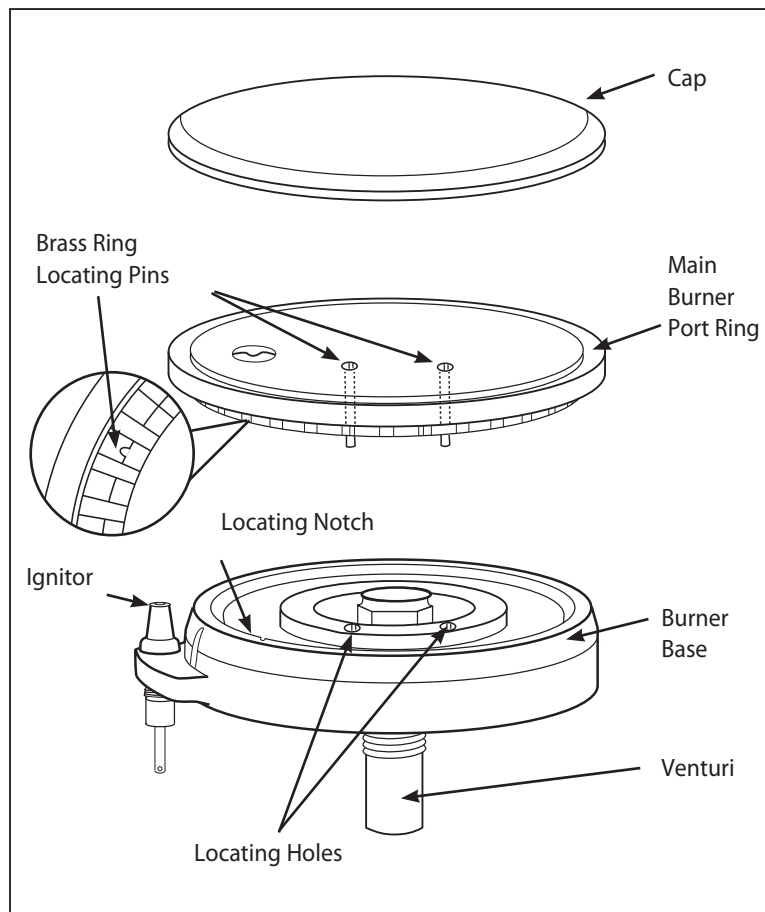

FIG. 59

TROUBLESHOOTING

BEFORE CALLING FOR SERVICE:

If the grill does not function properly, use the following checklist before contacting Customer Care to arrange for service. You may save the cost of a service call. Troubleshooting is for general purposes only. If the problem persists and you feel you require service, contact Customer Care. Only authorized agencies can perform warranty service. See section 'Service' for contact details.

GRILL WON'T LIGHT WHEN THE IGNITION BUTTON IS PUSHED:

- Is the gas supply turned on?
- Ensure the grill is cool. Remove the grill top grates and the ceramic radiant trays, watch the ignitor tip. You should see a spark jump from the tip of the ignition when the ignition button is pushed.
- If there is no spark when ignition button is pushed, check the battery condition. Battery condition should be checked at least once a year.
- Attempt to match light the burner (see section 'Lighting instructions'). Check to see that other burners on the unit operate. Clean ignitor tip of any debris.

BURNER FLAME IS YELLOW OR ORANGE, IN CONJUNCTION WITH THE ODOUR OF GAS:

- Check the burner inlet for obstructions such as spider webs. Check the air shutter for proper adjustment.
- Grill may be in a dusty area. Move to less dusty area if possible.

LOW HEAT WITH KNOB IN "HI/SEAR" POSITION:

- If only one of the burners appears low, clean the injector and burner, clearing ports of any obstruction (see section 'Care and maintenance').
- Grill may be in a dusty area. Move to less dusty area if possible.
- Check for proper gas supply and pressure.
- Pre-heat grill for a full 15 minutes.
- If using LPG gas, check for empty cylinder.

ROTISSERIE WON'T LIGHT:

- Is the gas supply turned on?
- Is there a spark at the ignitor?
- Does the rotisserie burner light when attempting to light with butane lighter?

ROTISSERIE LIGHTS, BUT WILL NOT HOLD FLAME ONCE BUTTON IS RELEASED:

- Continue holding safety valve button in depressed position until burner remains lit when released.

SERVICE

For warranty service and to purchase replacement parts, please contact Customer Care. To arrange for service under warranty, please have the following information ready:

- Model number*
- Serial number*
- Part number*
- Date of installation
- A brief description of the problem

*these can be found on the serial label behind the drip pan handle on the right-hand side.

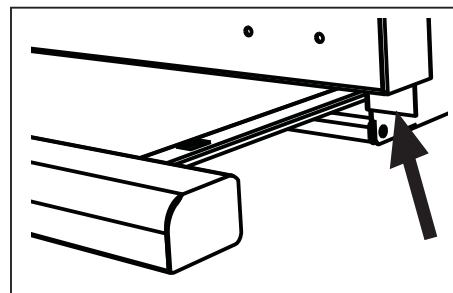

CONTACT US THROUGH OUR LOCAL WEBSITE

New Zealand www.fisherpaykel.co.nz/customer-care or www.dcsgrills.co.nz

Australia www.fisherpaykel.com.au/customer-care or www.dcsgrills.com.au

CALL US TOLL-FREE, 24/7

New Zealand 0800 372 273

Australia 1300 650 590

WRITE TO US

New Zealand Fisher & Paykel Appliances Limited
PO Box 58546
Botany, Auckland 2163
fax: (09) 273 0656
email: customer.care@fp.co.nz

Australia Fisher & Paykel Customer Services Pty
PO Box 798,
Cleveland,
QLD 4163
fax: + 61 7 3826 9298
email: customer.care@fp.com.au

WARRANTY

2

You receive a 2 year Manufacturer's Warranty with this product. Fisher & Paykel Appliances will repair (or at its option replace) any part which is found to be defective within TWO YEARS from date of purchase, without cost to you for either parts or labour.

+13

You also receive an additional THIRTEEN YEAR parts only warranty on your Stainless steel grill cover, Burner box, Cooking grates, Grill racks (Excluding discoloration or surface corrosion). This additional 13 year warranty commences on the day following the expiry of the two year manufacturer's Warranty and excludes labour.

+3

You also receive an additional THREE YEAR parts only warranty on your Stainless steel grill burners, stainless steel side shelf elements, stainless steel grill cart elements and all Cast Alloy parts (Excluding discoloration or surface corrosion). This additional 3 year warranty commences on the day following the expiry of the two year manufacturer's Warranty and excludes labour.

Fisher & Paykel Appliances will repair (as to parts) or, at its option replace any part which is found to be defective within the additional warranty periods. You will be responsible for any labour costs, including applicable call-out or service fees and freight.

THIS WARRANTY DOES NOT COVER

A Service calls which are not related to any defect in the Product. The cost of a service call will be charged if the problem is not found to be a Product fault. For example:

1. Correcting the installation of the product.
2. Instructing you how to use the product.
3. Replacing house fuses or incorrect house wiring or plumbing.
4. Correcting fault(s) caused by the user.
5. Noise or vibration that is considered normal, e.g. drain/fan sounds, regeneration noises or user warning beeps.
6. Correcting damage caused by pests, e.g. rats, cockroaches etc.

B Defects caused by factors other than:

1. Normal domestic use or
2. Use in accordance with the Product's User Guide.

C Defects to the Product caused by accident, neglect, misuse or Act of God.

D The cost of repairs carried out by repairers other than Fisher & Paykel Authorised Repairers or the cost of correcting such unauthorised repairs.

E Normal recommended maintenance as set out in the Product's User Guide.

F Repairs when the product has been dismantled, repaired or serviced by other than a Fisher & Paykel Authorised Repairer.

G Pick-up and delivery.

H Transportation or travelling costs involved in the repair when the product is installed outside the Fisher & Paykel Authorised Repairers normal service area.

WARRANTY (continued)

To make a claim under any warranty,

call customer care 1300 650 590.

Or email aus.customercare@fisherpaykel.com.

Service under any warranty must be provided by an authorised Fisher & Paykel Appliances Service provider. Used other than in accordance with the products user guide and other than for normal domestic use may invalidate any warranty. This warranty is an extra benefit and does not affect your legal rights.

Our goods come with guarantees that cannot be excluded under the Australian Consumer Law. You are entitled to a replacement or refund for a major failure and for compensation for any other reasonably foreseeable loss or damage. You are also entitled to have the goods repaired or replaced if the goods fail to be of acceptable quality and the failure does not amount to a major failure.

To view full terms and conditions, visit www.fisherpaykel.com.au/DCS.

You must retain your original proof of purchase. Failure to produce proof of purchase when requested may, at Fisher & Paykel's discretion, invalidate your claim. The warrantor is: Fisher & Paykel Australia Pty Ltd, 16 Parramatta Road, Lidcombe, NSW 2141. Ph Customer Care: 1300 650 590 Email: aus.customercare@fisherpaykel.com.

www.fisherpaykel.com



Copyright © Fisher & Paykel 2013. All rights reserved.

The product specifications in this booklet apply to the specific products and models described at the date of issue. Under our policy of continuous product improvement, these specifications may change at any time. You should therefore check with your Dealer to ensure this booklet correctly describes the product currently available.